



(806) 745-9221  
(806) 745-9200 Fax

2714 B 82nd St.  
Lubbock, TX 79423  
www.genesisair.com

## CREATING CLEAN AIR TO BREATHE 2002BSS Portable Blower Unit

Your current heating and cooling system is designed to remove large particles to prevent damage to the system itself, but does not stop the flow of smaller particles that can be harmful if inhaled into your lungs. The same system also provides a breeding ground for bacteria, mold, spores and fungi.

A Genesis Air system utilizes **GAP™** technology, a three-stage germicidal and air cleaning process that can trap particles down to .3 microns in its primary filtering stage. The second stage uses Ultraviolet light to neutralize and destroy organic contaminants such as airborne bacteria and viruses. The third stage uses the power of a photocatalyst section to safely convert dangerous chemical particles into benign components.

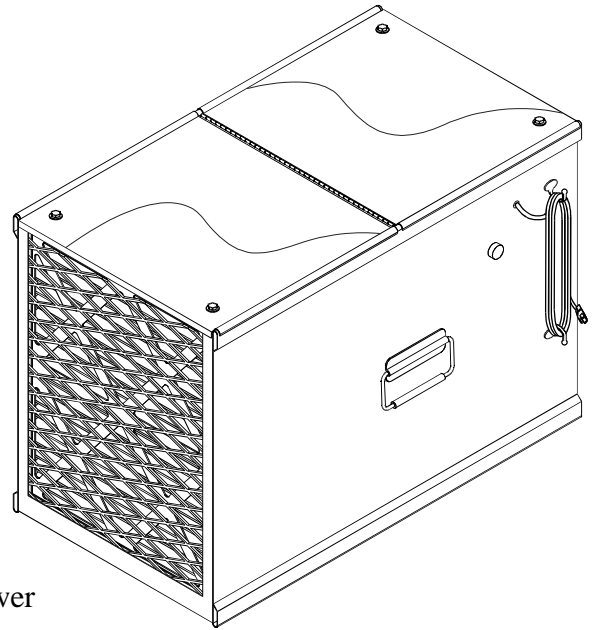

**The 2002BSS unit is a practical and highly effective tool to rapidly improve your air quality and**

### Case Studies on Air Pollution

*“Indoor air pollution is widespread. You are more likely to get sick from pollution in your home and office than from pollution in the air outside.” - The American Lung Association*

*“Indoor air is up to 100 times worse than Outdoor Air.” - EPA Report*

*“50% of all illness is caused by indoor air pollution.” - United States Environmental Protection Agency*

### Improves Health and Productivity

- Removes Odors
- Improves the Operation of HVAC Equipment
- Continuous Protection 24/7
- Kills Airborne Bacteria
- Reduces Carbon Monoxide (CO)
- Removes pollen, mold spores, mildew, ragweed, dust mites pet dander and many other irritants.

**Uses Two 36W UVCGI Lights  
Dual Catalyst Design Offers Superior Air Purification  
Variable Speed Blower  
Stainless Steel Construction**

### 1 ADVANCED FILTRATION

Removes even particles you can't see. New, high-efficiency, high-capacity, low resistance particle filter removes most pollen, mold, mildew, ragweed, dust mites, house dust, bacteria, pet dander and many other submicroscopic poisons, allergens and irritants

### 2 UVGI TECHNOLOGY

10,000 times the power of the Sun, eradicate most airborne bacteria, viruses, mold, spores, and fungi. Genesis Air Photocatalysis (GAP™) uses ultraviolet germicidal light in a dual role to destroy and neutralize microorganisms and to activate the photocatalyst, which removes toxic chemical compounds, neutralizes odors, and vaporizes organic matter.

### 3 GENESIS AIR PHOTOCATALYSIS

(GAP™) - Converts and breaks down harmful chemical vapors and odors. Titanium Dioxide in the presence of UV light has a natural purifying effect on organic compounds, odors, and toxic gases of all kinds. Its oxidizing effect converts chemical and biological contaminants into benign elements - carbon dioxide and water vapor.



(806) 745-9221  
(806) 745-9200 Fax

2714 B 82nd St.  
Lubbock, TX 79423  
www.genesisair.com

## CREATING CLEAN AIR TO BREATHE 2002BSS Portable Blower Unit

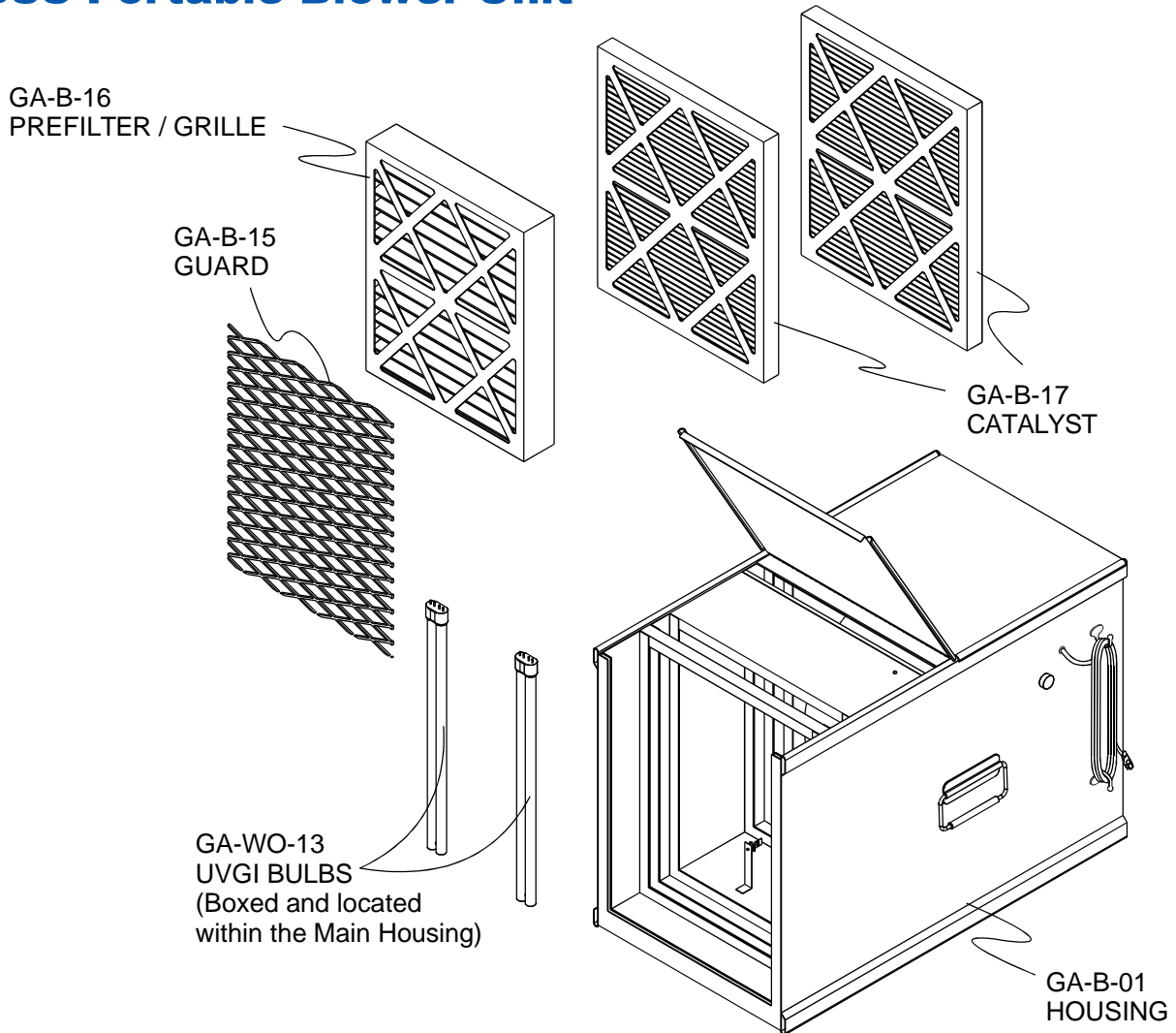

### Specifications:

Unit Designed for use in any room or office space  
Prefilter / Grille required: Standard MERV 12  
Type of Catalyst: Dual TiO<sub>2</sub> Coated Pleated Fiberglass Mesh  
The Catalyst Is Designed To Offer 2,000 Sq. Inches of Surface Area  
Uses Two (2) 36W UVC GI Lights For Germicidal Protection  
Plugs Into A Standard 120V Outlet  
Heavy Duty Casters Provide Easy Transport  
Variable Speed Blower  
Stainless Steel Construction

### Air Flow Resistance:

Filter: .16 in.  
Catalyst: .006 in.

Overall Dimensions  
21" x 27 1/2" x 37 1/2"