



**Indoor Air Purifier**  
**Condor / Beast**

Standalone / Portable / Ducted

Commercial

CenterPoint Photocatalytic Oxidation Technology



## Product Description

The Condor is a stand-alone unit used to reduce the levels of Volatile Organic Compounds (VOC's) and viable airborne biological contaminants. The unit may be utilized as a roll-around "point-of-use" air purifier or may be ducted for permanent installations. The Condor uses (1) to (4) 2021 Populated Catalyst Panel(s). The Condor may also be equipped with a 20" x 24" x 6" HEPA filter or 20" x 24" x 12" V-Bank Carbon Filter. The Condor is suitable for spaces up to 3,250 square feet. For recommend configurations, consult the manufacturer's engineering department.

*Refer to page 8 for performance at different room sizes.*

## Suitable Locations

- Medical Facilities, Education Facilities, Restaurants, Hotels, Smoking Environments, Office Spaces, Residential, Green Houses, and Hydroponics Facilities.

## Shipping and Packing List

Standard Equipment:

- (1) Condor Housing
- (0) to (4) 2021 PCP(s)
- (1) 20" x 24" x 4" MERV 13 Pre-filter
- (1) 24" x 20" UV Shielding

Features:

- Variable Speed Control
- Caster Wheels
- Lifting Handles
- Powder Coated Exterior

Optional Equipment:

- Hinged Lid
- 20" x 24" x 6" HEPA Filter
- 20" x 24" x 6" MERV 15 Filter
- 20" x 24" x 12" V-Bank Carbon Filter

## Copyright

Genesis Air, Inc. is the owner of this document and the information it contains. The manufacturer reserves the right to revise this publication at any time and make changes to its content without obligation to notify any person of such revision or change.

## Revision Summary

Original IOM manual created in November 2019.

Manual last revised on July 1<sup>st</sup>, 2024.

# Table of Contents

Product Description / Suitable Locations	2
Shipping and Packing List	2
Copyright / Revisions Summary	2
Safety Certifications	4
Warning Labels	5 – 6
Product Overview	7
Specifications	8
UV Lamp Information	9
Installation	10 – 14
Operation	14
Unit Sizing	15
Maintenance	16 – 32
Pre-filter Replacement	16
HEPA Filter Replacement	17
Carbon Filter Replacement	18
Lamp Replacement	19 – 21
Lamp Disposal	21
Ballast Troubleshooting	22
Ballast Replacement	23 – 24
Fan Motor Replacement	25 – 26
Catalyst Cleaning	27 – 28
Catalyst Replacement	29 – 30
Fuse Replacement	31
Replacement Parts	32
Wiring Diagram	33 – 37
Air Purification Testing	38
Warranty	39 – 40

## Safety Certifications

UL Classified UL File No. E326567

FIFRA....EPA EST No. 87747--TX--001





### UL Requirements

- 105°C minimum supply connection rating.
- For catalyst marked “XXXX”, 50°C/122°F maximum ambient temperature. For those marked “XXXX-E”, 80°C/176°F maximum ambient temperature.
- Access above ceiling may be required.
- The health aspects associated with the use of this product and its ability to aid in disinfection of environment air have not been investigated by UL.
- Only use type T5 lamps specified by the PCP manufactured by First Light Technologies, Inc., UV Engineering Solutions LLC., or Light Source, Inc.
- **Caution:** *Equipment Damage Hazard. Ultraviolet light can cause color shift or surface degradation and sometimes structural degradation of non-metallic components. Select mounting location rubber hoses, wiring insulation, filtration media, etc. If mounting options are limited, items above should be protected with ultraviolet resistant materials such as aluminum foil, aluminum duct tape or metallic shields.*
- **Caution:** Some air filters can capture flammable gasses or materials.
- **The manufacturer (Genesis Air) does not take responsibility for flammable gases or materials which are captured by air filters in the device. The manufacturer (Genesis Air) does not recommend the use of filters which have not been tested according to UL900 or do not meet spark test requirements. Add-on filters, not provided by the manufacturer, should not be used in this device. The manufacturer (Genesis Air) does not take responsibility for any fires created by the device or created by air filters in the device.**

CARB Certified Air Cleaning Device....EO No. G-11-040

**Meets California ozone emissions  
limit: CARB certified**

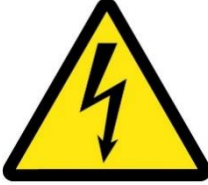
## Warning Labels

	<p><b>⚠️WARNING</b></p> <p><b>Electric / Shock Hazard</b> Electrical Shock can cause serious injury or death. Disconnect all remote electrical power supplies before servicing.</p>	<p><b>⚠️WARNING</b></p> <p>To reduce the potential of electric shock or fire, the wiring required by this manual should be performed by a licensed electrician in accordance with applicable National Electric Code, NFPA 70, and local codes.</p>
	<p><b>⚠️WARNING</b></p> <p>UVC Light hazard. UVC light can cause temporary or permanent loss of vision and sunburn. Take proper precautions to protect eyes and skin from direct exposure. Replace lamp with Model No. 2813, Manufactured by First Light Technologies, Inc., or lamp with Model No. GEN9093, Manufactured by UV Engineering Solutions LLC.</p>	
<p><b>⚠️WARNING</b></p> <p><b>Mercury Hazard</b> Do not break lamps. Each UVC lamp contains a small amount of Mercury. In case of breakage use proper lamp disposal techniques on page 13.</p>	<p><b>⚠️WARNING</b></p> <p>Improper installation, adjustment, alteration, service, or maintenance can cause property damage, personal injury, or death. Installation and service must be performed by a qualified installer or service agency.</p>	
<p><b>⚠️WARNING</b></p> <p><b>TO REDUCE THE RISK OF FIRE, ELECTRIC SHOCK, OR INJURY TO PERSONS, OBSERVE THE FOLLOWING:</b></p> <p>a.) Use this unit only in the manner intended by the manufacturer. If you have questions, contact the manufacturer.</p> <p>b.) Before servicing or cleaning unit, switch power off at service panel and lock the service disconnecting means to prevent power from being switched on accidentally. When the service disconnecting means cannot be locked, securely fasten a prominent warning device, such as a tag to the service panel.</p>		

**⚠WARNING**

Use of accessories, transducers, and cables other than those specified or provided by the manufacture of this equipment could result in increased electromagnetic emissions or decrease electromagnetic immunity of this equipment and result in improper operation.

**⚠WARNING**

Portable RF communications equipment (including peripherals such as antenna cables and external antennas) should be used no closer than 30 cm (12 inches) to any part of the unit, including cables specified by the manufacture. Otherwise, degradation of the performance of this equipment could result.

**⚠WARNING**

**Keep Away from Water Danger**

As with most electrical appliances, electrical parts in this device are electrically live even when dial is switched off. To reduce risk of death by electric shock:

1. Always “unplug it” after use
2. Do not place or store where device can fall or be pulled into water.
3. do not use near or place in water.
4. If device falls into water, unplug immediately. Do not reach into water.

**⚠WARNING**

Children should be supervised to ensure that they do not play with the appliance.

**⚠WARNING**

**Do Not Stack**

Use of this equipment adjacent to or stacked with other equipment should be avoided because it could result in improper operation. If such use is necessary, this equipment and the other equipment should be observed to verify that they are operating normally.



**NOTICE**

**Do Not Block Air Grille**

Blocking inlet or exhaust grilles may result in improper operation of air cleaning equipment. Overheating may result and cause permanent damage to equipment.

**⚠WARNING**

This appliance is not intended for use by persons (including children) with reduced physical, sensory, or mental capabilities, or lack of experience and knowledge, unless they have been given supervision or instruction concerning use of the appliance by a person responsible for their safety.

# Product Overview

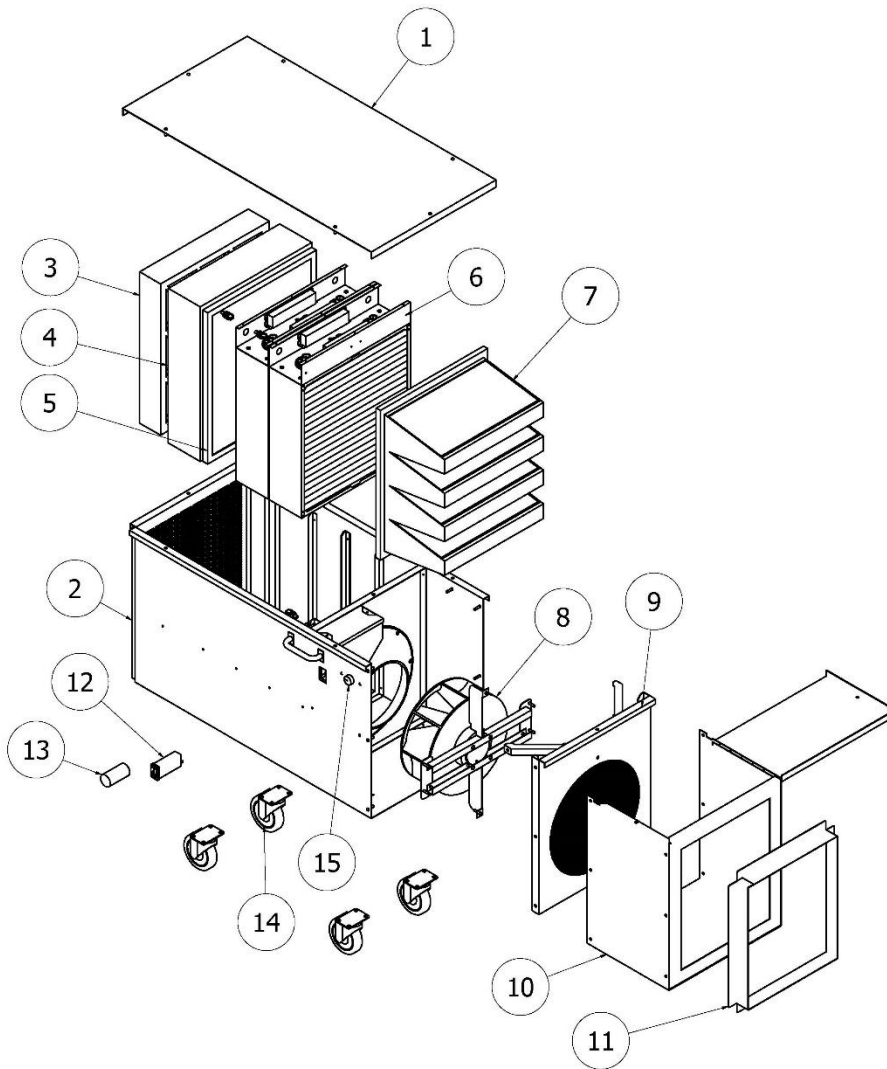

**Figure 1: Components of the Condor**

**1.) Lid**

**2.) Shell**

**3.) Pre-Filter** – 20" x 24" x 4"  
MERV 13.

**4.) HEPA Filter** – 20" x 24" x 6"  
HEPA (Optional).

**5.) UV Shielding** – 20" x 24" x  
1" metallic filter

**6.) 2021 PCP** – CenterPoint  
Technology. Contains ballast  
tray, 20" UVC lamps and  
catalyst mesh.

**7.) Carbon Filter** – 20" x 24" x  
12" V-Bank, 50/50 mix  
(Optional).

**8.) Fan Motor** – 355mm  
impeller, PSC Motor, 120VAC

**9.) Outlet Grille**

**10.) Carbon Filter Extension** –  
encases carbon filter (Optional).

**11.) Supply Duct Collar** –  
(Optional)

**12.) Power Entry Module** –  
includes power cord plug, fuses,  
and main disconnect.

**13.) Capacitor** – 40MFD

**14.) Caster Wheels**

**15.) Steady State Speed  
Control** – Fan speed control.

*Report missing or damaged parts to the manufacturer. Refer to warranty for more information.*

## Specifications

**U.S. Patent Number:** 10946116

**Model Numbers:** B0, B1 / B2 / B3 / B4

**Volumetric Flow Rate (CFM):** 850 (Low Speed) – 1,625 (High Speed)

**Power Requirements:** 120 Volts, 60 Hertz

**Current (amps):** 6.45 / 7.50 / 8.55 / 9.60

**Weight (lbs.):** 163 / 174 / 185 / 197

**Size:** 22.5" x 30.25" x 44.5"

**Number of Lamps:** 3 / 6 / 9 / 12

**UVGI Life Cycle:** 12,000 operational hours

**PCP Life Cycle:** 5 years\*

**Standard Pre-filter:** 20" x 24" x 4" MERV 13

**Installation Type:** Portable or Ceiling Mounted

**Temperature Rating:** -20°F to 122°F

**Sound Level (dB from 3 ft away):** 61 (Mid-Range) – 76 (High Speed)

*\*Equipment must be properly maintained to allow Catalyst Panels to last the full 5-year warranty period. If MERV particle filters are not used or are not replaced at the appropriate intervals, the life of the catalyst panels will be reduced. If PCPs are cleaned incorrectly or too frequently, the life of the catalyst panels will be reduced. **High pressure spray cannot be used directly on Catalyst Panels.** Performing maintenance improperly will result in a voided product warranty. Catalyst can exceed warranty and last up to 15 years if well maintained.*



# UVC Lamps

## Safety

Ultraviolet germicidal irradiation (UVGI) is used for the activation of the PCO Catalyst. The residual light presents a variety of potential health hazards to humans. These hazards include eye damage, skin burns, and the potential to cause skin cancer. Because germicidal UV rays are invisible to the human eye, personnel may be subjected to a hazardous dose of UV without warning. There is no Occupational Safety and Health Administration standard for exposure to ultraviolet light. UV can be associated with adverse health effects depending on duration of exposure and wavelength. These adverse health effects include erythema (sunburn), photokeratitis (a feeling of sand in the eyes), skin cancer, melanoma, cataracts, and retinal burns. Ideally, activated UV sources should be always attended by knowledgeable personnel. The UVC lamps in CenterPoint products do not produce ozone! The lamps provided contain trace amounts of mercury. Lamps include a Teflon case to encapsulate the lamp and reduce the risk of exposing the consumer and environment to mercury.

## Malfunctions

In the event of a lamp or ballast malfunction or failure, failed components should be salvaged and sent back to the manufacturer for investigation. The manufacturer may consider sending new components under warranty if malfunctioning components are sent back to the manufacturer.

## Personal Protective Equipment

While in normal operation, the unit will not emit harmful levels of UV radiation to the surrounding area. When checking for proper lamp connection and lamp intensity, you may be exposed to harmful levels of UV radiation. If you must have the lamps on to check for proper operation, follow these instructions.

- All personnel exposed to UV radiation must wear UV protective glasses.
- All personnel exposed to UV radiation must protect exposed skin with UV resistant clothing.

## UVC Lamp Test Procedure

Lamps may not be substituted with an unapproved manufacturer. These lamps provide UV-C light at a wavelength of 254 nm. Despite their appearance to the naked eye, the lamp intensity will reduce over time. A 20% reduction in UV output is considered below the minimum acceptable intensity level. A visual inspection alone cannot be used to determine if a lamp is providing the correct level of UV energy. Replace lamps every 16 months (12,000 hrs.) of continuous use to maintain intensity requirements. If the run time of the equipment is unknown, use one of the recommended lamp test procedures recommended by the manufacturer.

# Installation

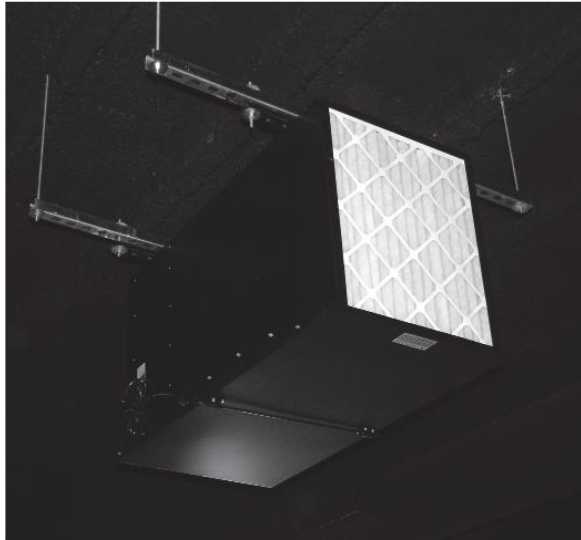

Figure 4: Standalone Ceiling Mounted

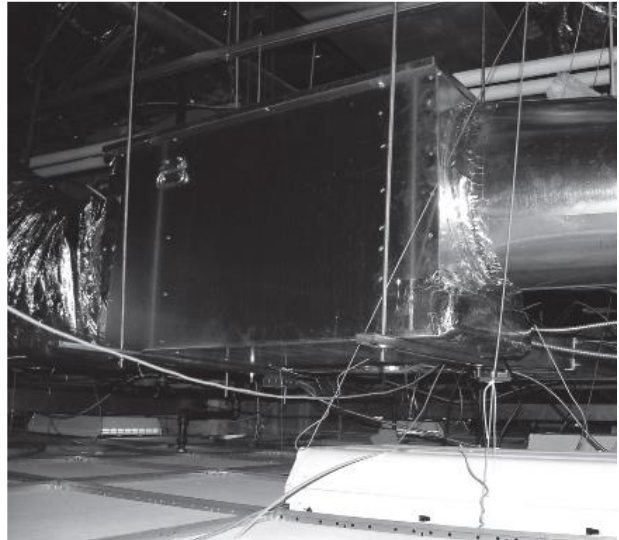

Figure 5: Ducted Above Ceiling Tiles

## WARNING!

### Sharp Edges Hazard

Equipment with sharp edges can cause injuries. Use protective gloves when grasping the edges of equipment.

## WARNING!

Do not use silicone to seal Condor to ductwork. The presence of silicone in UV light will pollute the catalyst.

The Condor is designed to be utilized either as a portable or permanently installed unit. Installation must be completed by competent personnel. The manufacturer assumes no liability for damages or injuries sustained from installations done by persons other than qualified technicians who are employed by the manufacture.

### Portable Installation

Make the following considerations when choosing an appropriate placement location.

- Choose a suitable location on the ground within a room or corridor that requires air purification.
- Ensure that the intake and outlet grills of the unit are not blocked by adjacent furniture or walls.
- Ensure that the placement of the unit does not interfere with the flow of foot traffic or block entrances or exits to rooms within the building.
- Placing air purifier too close to a window or door may cause unit to suck in outdoor air rather than recirculate air in the room.

**Caution:** *Placing the Condor in a location on the floor that impedes foot traffic may be considered a fire hazard. Consults local building and fire codes to find a suitable floor location.*

- Choose a location that has access to a 120V power outlet. An extension cord with ground pin may be used if the supplied power cable is too short for your application.

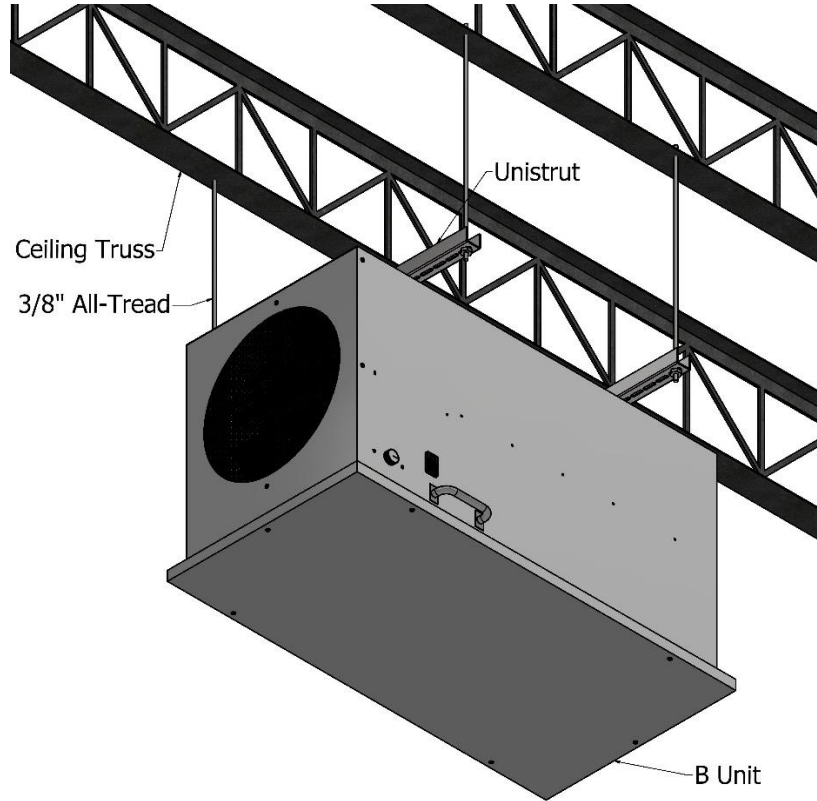

**Figure 6: Non-Ducted Ceiling Mounting**

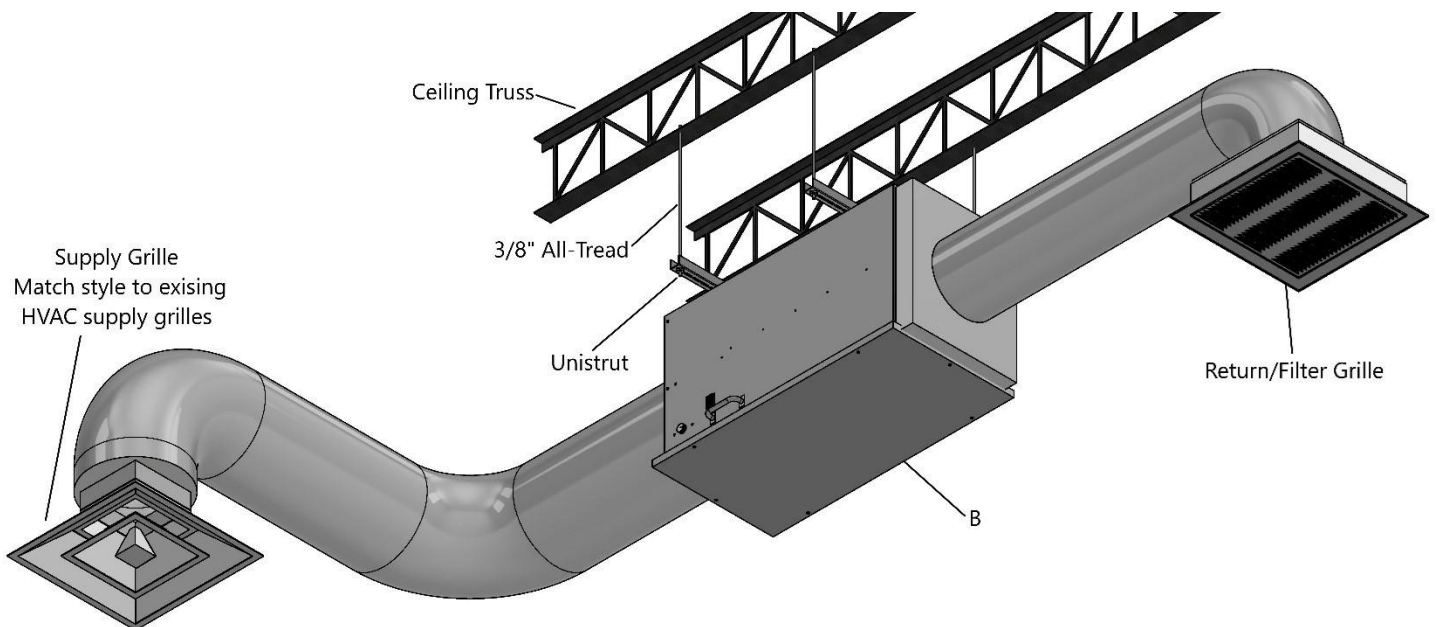

**Figure 7: Ducted Ceiling Mounting**

## Permanent Ceiling Installation

Make the following considerations when choosing an appropriate placement location.

- The presents of structural components that will be needed to hold the Condor in place.
- Access to 120V AC power supply.
- Other fixtures in the vicinity of installation.
- Clearance from preexisting ductwork, beams, sprinklers, lights, or other above-ceiling fixtures.
- Return and supply grille locations.
- Ease of access for maintenance personnel.
- Install supply grill at least 10 feet away from return/filter grille.

1.) Determine a suitable location for the Condor above or below the drop-tile ceiling grid.

2.) Remove caster wheels from the base of the Condor.

3.) Attach Unistrut to the bottom of your Condor in place of the caster wheels. The Unistrut should extend 4" on either side of the Condor and be able to support 250 lb.

4.) Make an opening in the ceiling grid to allow the Condor to be lifted into place.

5.) Attach another pair for Unistrut to the roof truss.

6.) Using a lift, move the Condor into position. The Condor should be installed so that the lid can be easily accessed for maintenance. Installing the unit upside down is recommended for easier access. The unit may also be hung sideways.

7.) Use 3/8" All-tread to bolt the Unistrut on the condor to the Unistrut on the roof trusses. Ensure that the unit is level and not twisted.

Skip to step 11 if duct work will not be installed. See Figure 6.

8.) Attached duct collar the supply and return end of the Condor using self-tapping screws and metallic tape.

9.) Locate a place to install the return grill near the Condor intake. Be sure to use good judgement by choosing a location with clearance from permanent duct work, beams, lights, sprinklers, or other above-ceiling fixtures.

10.) Lift the return/filter grill section up above the ceiling tiles. You may need to angle the grille so that it will fit through the ceiling grid. Set the grill unit onto the grid carefully. Use the same guidelines to add more return or supply grilles as necessary.

**Note:** *Supply and return grilles not included. For consistency, it is normally recommended to choose grilles that match the preexisting HVAC system grilles.*

11.) Attach ductwork as shown in Figure 7. Insulating the exterior of the Condor is recommended if it is installed in locations that are not climate controlled. These locations include ducts in attics, on top of roofs, and on the side of buildings.

**Caution:** If the Condor is exposed to fluctuating temperatures, water may condense on the interior or exterior of the duct. Condensation can cause corrosion and mold growth.

**Caution:** Uninsulated ductwork can allow heat to be transferred between the duct and external air. This can result in an unnecessary strain on the buildings' HVAC system.

**Caution:** Leaks in ductwork can result in attic air being pumped into the space. This can result in an unnecessary strain on the buildings' HVAC system.

**Note:** If ductwork is altered, installer must ensure that no leakage of UV light occurs because of ductwork modifications! The Condor is a standalone device, not designed to be integrated into the existing building HVAC ducts!

12.) Connect unit to power. Plug in power cord to a 120 VAC power supply. The Condor can also be hard wired. See Hard Wiring Instructions.

13.) Power on unit and check for leaks in duct work. All leaks should be sealed with metallic tape.

### Hard Wiring Instructions

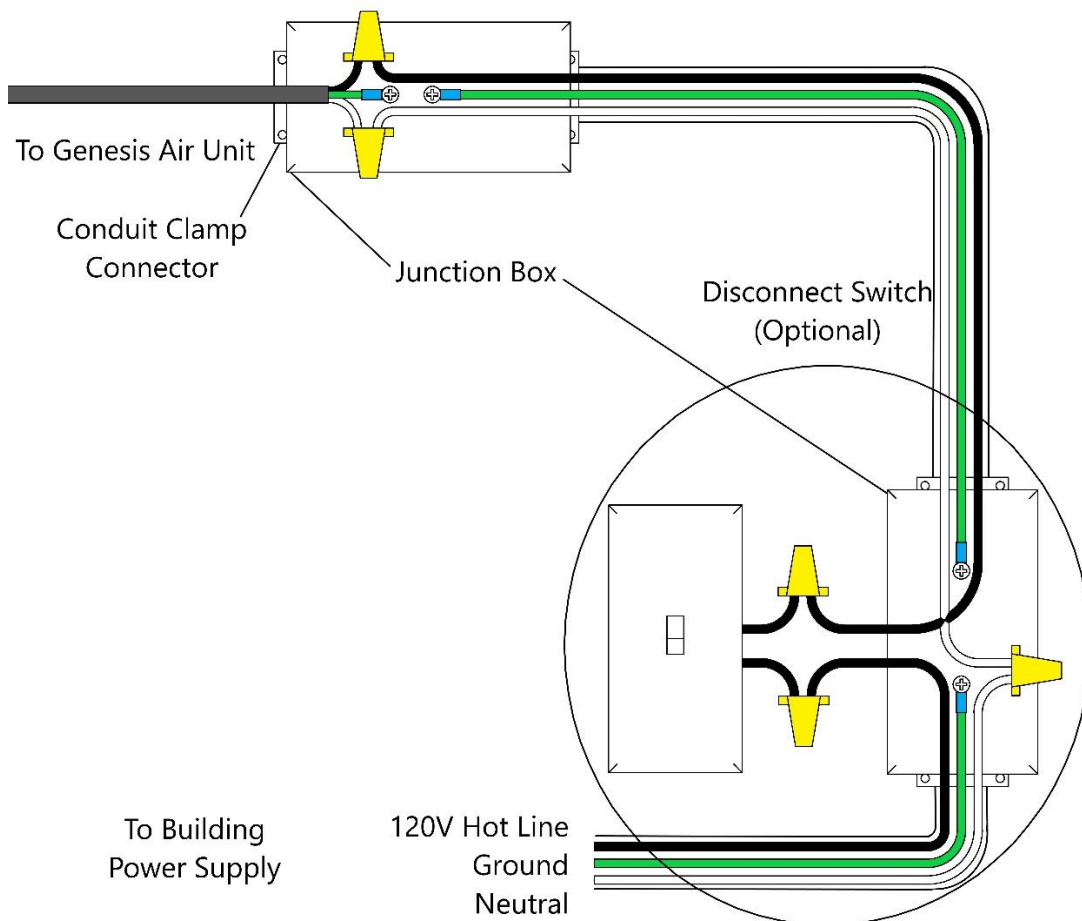
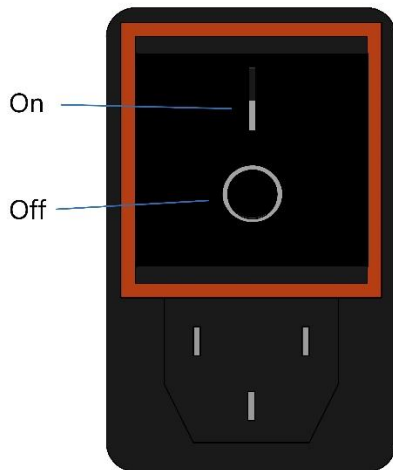

**Figure 8: Hard Wiring Diagram**

**Caution:** To reduce the potential of electric shock or fire, the wiring required by this manual should be performed by a licensed electrician in accordance with applicable National Electric Cod, NFPA 70, and local codes.

- Use a 16 AWG, type C13 power cord.
- Run a building circuit to the location of the Condor and install a junction box. 12 AWG wire is preferred.
- A single pole toggle switch may be installed and used as a local shut off switch.
- Use wire nuts to connect the ends of the power cord to the leads in the junction box.
- Energize circuit breaker once all wires have been connected.

## Operation



**Figure 9: Power Entry Module**

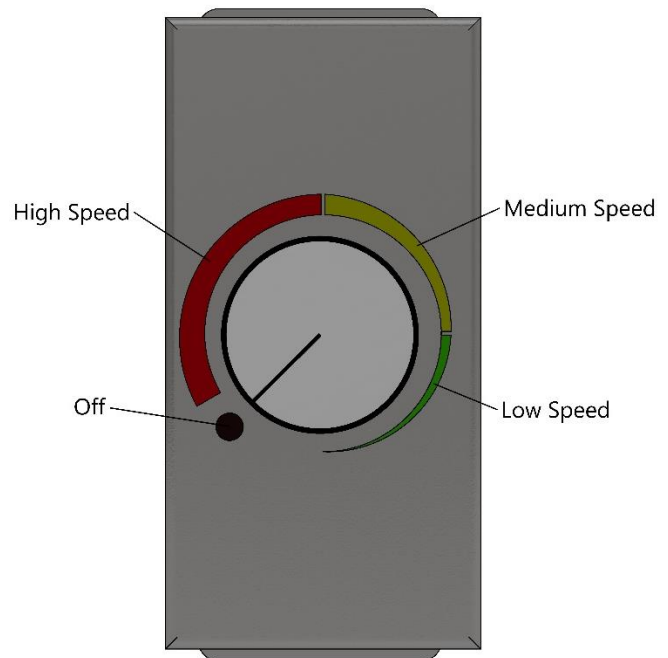

**Figure 10: Motor Controller**

### Power Entry Module:

The Power Entry Module is the main power switch for the unit. Click to the “I” position to turn on and turn to the “O” position to turn off. See Fuse Replacement instructions for more information.

### Motor Controller:

Turn the knob on the Motor Controller to adjust the fan speed. Note that when turned from Off to On, the fan will start in the high-speed position. When turning off fan, be sure to feel knob “Click” to off position.

## Unit Sizing

Ceiling Height			Air Flow Rate (CFM)				
8 ft.	9 ft.	10 ft.	800	1,000	1,200	1,400	1,600
Room Size (sq.ft.)			Air Changes Per Hour				
1,000	889	800	6.00	7.50	9.00	10.50	12.00
1,500	1,333	1,200	4.00	5.00	6.00	7.00	8.00
2,000	1,778	1,600	3.00	3.75	4.50	5.25	6.00
2,500	2,222	2,000	2.40	3.00	3.60	4.20	4.80
3,000	2,667	2,400	2.00	2.50	3.00	3.50	4.00
3,500	3,111	2,800	1.71	2.14	2.57	3.00	3.43
4,000	3,556	3,200	1.50	1.88	2.25	2.63	3.00

**Table 1: Air changes per hour at different flow rates**

**Note:** *Highlighted Cells indicate unit range. See ASHRAE standard 62.1 for required ventilation for acceptable indoor air quality. CenterPoint devices do not deactivate or oxidize 100% of all contaminants in the air. Lower air speeds increase the effectiveness of the air purifier.*

**Note:** *CFM range shown for standard equipment. The air flow rate of customized units may vary.*

**Note:** *The manufacturer recommends 3 to 6 air changes per hour be performed by the Condor.*

# Maintenance

## Pre-filter Replacement

The Condor includes a pre-filter to remove particles from the air stream. The pre-filter should be replaced when it has become built up with dirt and other contaminants. The manufacturer recommends replacing filter with a 20" x 24" x 4" MERV 13 after 3 months of continuous use.

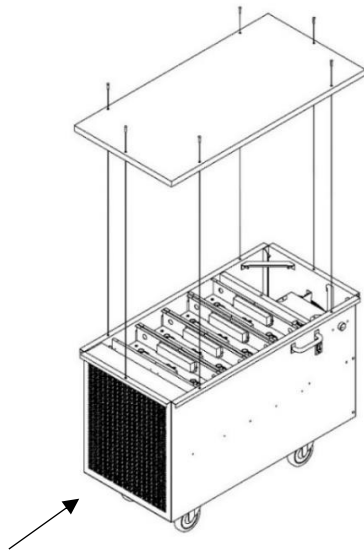

Direction of Air Flow

Figure 11

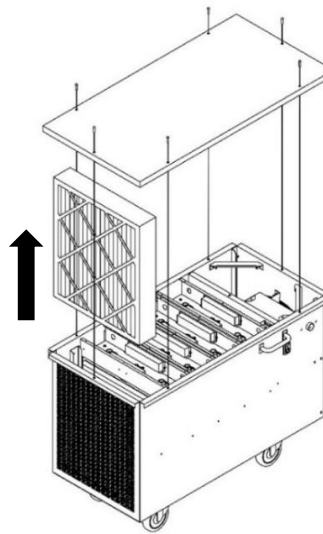

Figure 12

## Filter Replacement Procedure

1.) Disconnect unit from power supply.

**Note:** *If the unit is powered on during lid removal, a safety switch will disconnect power.*

**Caution:** *Electrical plug must be disconnected before servicing. A break in power caused by the safety switch is not considered disconnecting power.*

2.) Remove top lid by unscrewing (6) screws with a 3.5 mm Allen wrench. Condor fitted with a hinge will have fewer screws to remove. See Figure 11.

**Caution:** *If Condor has been installed upside down, internal components may fall out when the lid is removed.*

3.) Remove old air filter. See Figure 12.

4.) Inspect the new filter to ensure that it is the same size as the original filter.

5.) Insert new air filter. Ensure that arrows on filter match the direction of air flow.

6.) Reattach the lid and re-insert (6) screws and tightening with an Allen wrench.

7.) Plug-in unit and power on to ensure that the unit works properly.



## HEPA Filter Replacement

The Condor may also include a 20" x 24" x 6" HEPA filter. A HEPA filter can be selected as an option for the B1, B2, or B3.

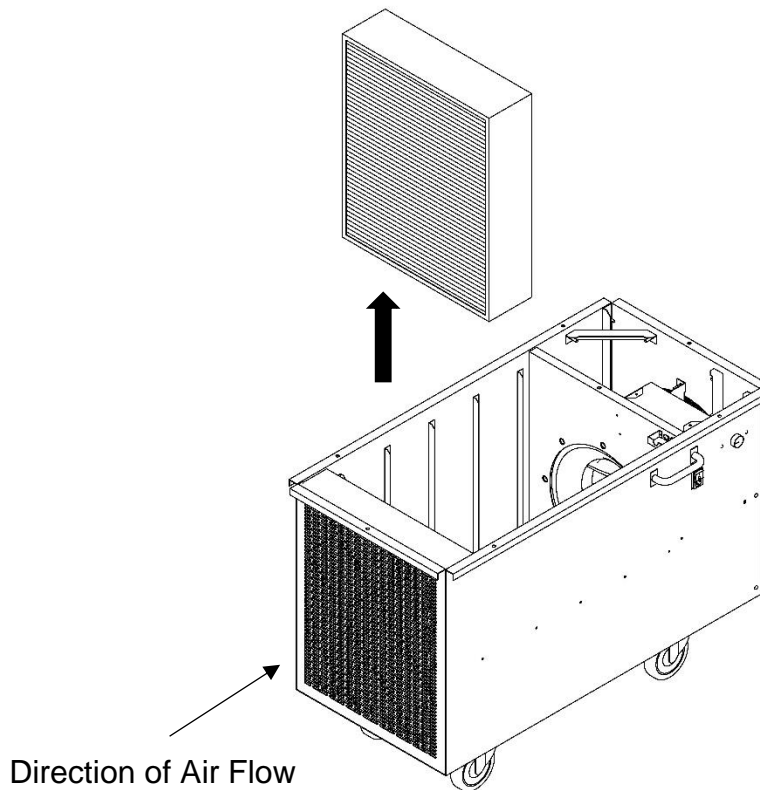

**Figure 13**

### HEPA Filter Replacement Procedure

1.) Disconnect unit from power supply.

**Note:** *If the unit is powered on during lid removal, a safety switch will disconnect power.*

**Caution:** *Electrical plug must be disconnected before servicing. A break in power caused by the safety switch is not considered disconnecting power.*

2.) Remove top lid by unscrewing (6) screws with a 3.5 mm Allen wrench. When fitted with a hinge, the Condor will have fewer screws to remove. See Figure 11.

**Caution:** *If the Condor has been installed upside down, internal components may fall out when the lid is removed.*

3.) Remove old HEPA filter. See Figure 13.

4.) Inspect new HEPA filter to ensure that it is the same size as the original filter (20" x 24" x 6").

5.) Insert new HEPA filter. Ensure that arrows on filter match the direction of air flow.

6.) Reattach the lid and re-insert (6) screws and tightening with an Allen wrench.

7.) Plug-in unit and power on to ensure that the unit works properly.

## Carbon Filter Replacement

Models named “Beast” will contain a Carbon V-Bank. This is a 20” x 24” x 12” V-Bank containing a 50/50 blend of Carbon and Potassium Permanganate. The filter may also contain carbon derived from coconuts. This filter should be replaced as needed based gas phase filter efficiency. The manufacturer recommends replacing this filter once per year. Replace with D-Mark Adsoball Carbon V-Bank Filter, model number AAC-12-100-06.

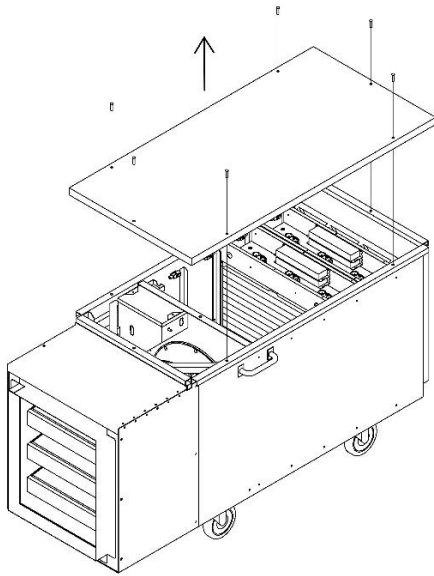

**Figure 14**

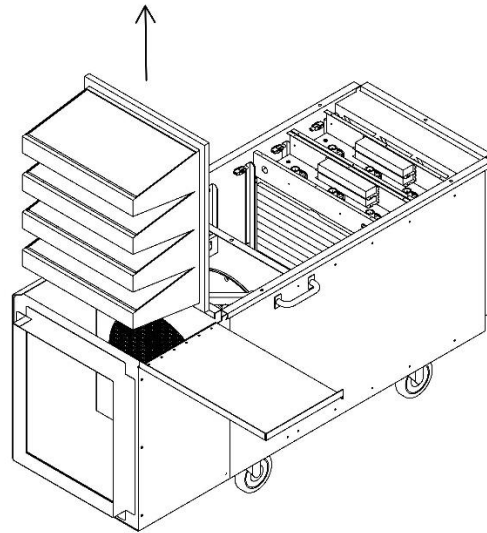

**Figure 15**

### Carbon Filter Replacement Procedure

1.) Disconnect unit from power supply.

**Note:** *If the unit is powered on during lid removal, a safety switch will disconnect power.*

**Caution:** *Electrical plug must be disconnected before servicing. A break in power caused by the safety switch is not considered disconnecting power.*

2.) Remove top lid by unscrewing (6) screws with a 3.5 mm Allen wrench. Condor fitted with a hinge will have fewer screws to remove. See Figure 14.

**Caution:** *If Condor has been installed upside down, internal components may fall out when the lid is removed.*

3.) Open carbon filter Lid

4.) Remove old carbon filter. See Figure 15.

4.) Inspect the new filter to ensure that it is the same size as the original filter.

5.) Insert new air filter. Ensure that arrows on filter match the direction of air flow.

6.) Reattach the lid and re-insert (6) screws and tightening with an Allen wrench.

7.) Plug-in unit and power on to ensure that the unit works properly.

## Lamp Replacement

The Condor includes 20" UVC lamps. These lamps are used to energize the catalyst. Each 2021 PCP contains (3) 20" lamps manufactured by First Light Technologies, Inc., UV Engineering Solutions LLC., or Light Sources, Inc. Lamps must be replaced after 12,000 hours of continuous use. The manufacturer recommends replacing lamps every 16 months or once a year.

### Lamp Replacement Procedure

1.) Disconnect unit from power supply.

**Note:** *If the unit is powered on during lid removal, a safety switch will disconnect power.*

**Caution:** *Electrical plug must be disconnected before servicing. A break in power caused by the safety switch is not considered disconnecting power.*

2.) Remove top lid by unscrewing (6) screws with a 3.5 mm Allen wrench. When fitted with a hinge, the Condor will have fewer screws to remove. See Figure 11.

**Caution:** *If the Condor has been installed upside down, internal components may fall out when the lid is removed.*

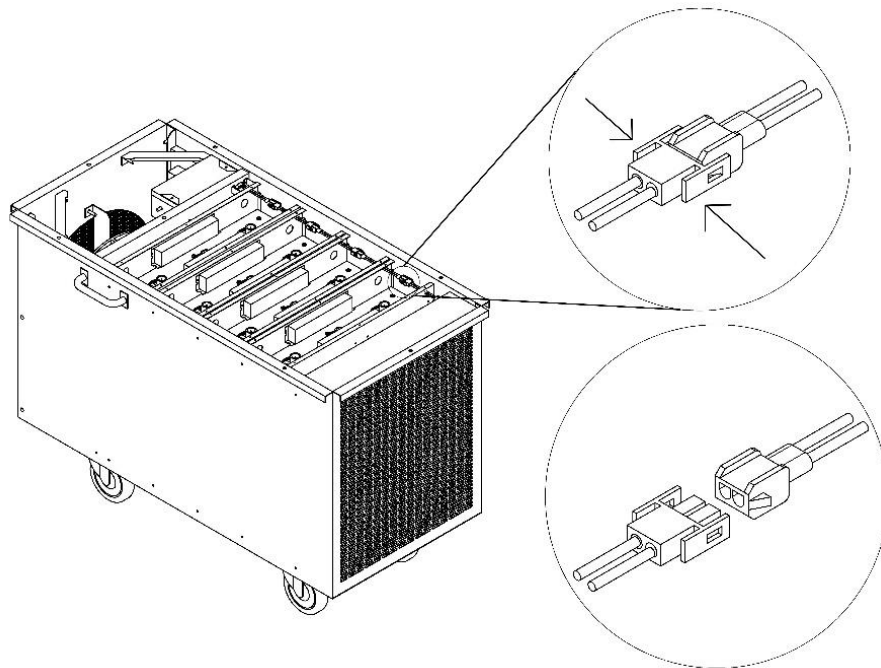

**Figure 16**

3.) Disconnect 2 pin MOLEX connector providing power to Catalyst Panel. See Figure 16.

4.) Remove catalyst panel(s) from the Condor. If the Condor has been installed upside down, remove the 10-16 Self-Drilling screws holding the catalyst panel(s) in place. Remove using a 5/16" socket. Be sure to hold panels while the screws are being removed to ensure that the panel does not fall out of housing.

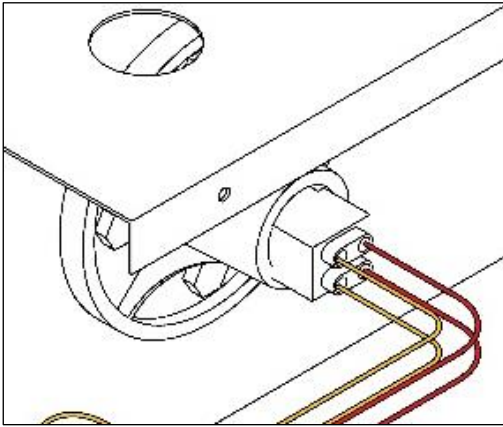

**Figure 17**

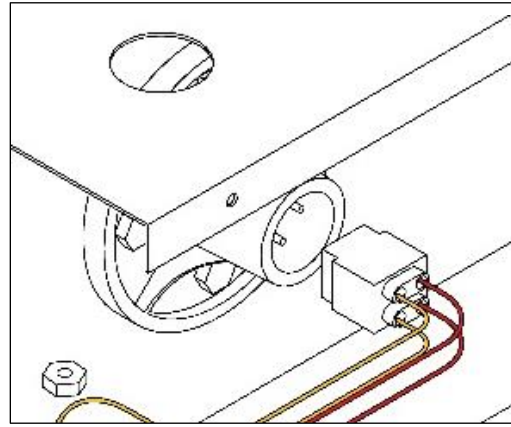

**Figure 18**

5.) Disconnect lamp plugs from lamps that will be replaced. See Figures 17 and 18.

**Caution:** When removing lamp plugs, avoid wiggling plugs. This can cause excessive wear on contact pins.

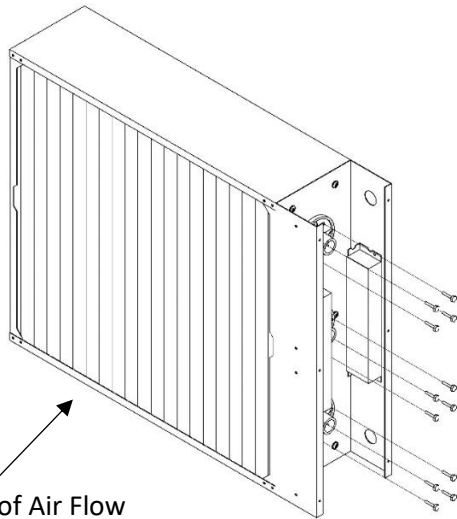

Direction of Air Flow

**Figure 19**

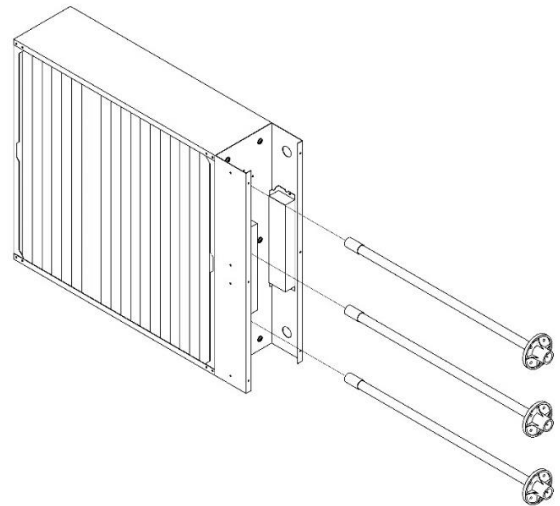

**Figure 20**

6.) Lamps are attached to Catalyst Panel with (4) 10-16 Self-Drilling screws per lamp. Remove the screws using a 5/16" socket. See Figure 19.

7.) Remove lamps by alternating a quarter turn clockwise and a quarter turn counterclockwise as it is pulled out. This will prevent the lamp from becoming bound up in the catalyst media. See Figure 20.

**Caution:** Lamps may be hot if recently in operation. Allow lamps to cool before removing or wear heat insulating gloves to protect hands.

8.) Inspect the new lamp to ensure that it matches the length of the original lamp.

9.) Replace lamps by alternating a quarter turn clockwise and a quarter turn counterclockwise as it is pushed in. This will prevent the lamp from becoming bound up in the catalyst media. See Figure 20.

10.) Reinsert (4) screws per lamp using a 5/16" socket. See Figure 19.

11.) Reconnect lamp plugs. See Figures 17 and 18.

12.) Place catalyst panel(s) back into the Condor. Be sure that arrows on panel point in the direction of air flow. If the Condor is installed upside down, reinsert the 10-16 self-drilling screws into their original holes, holding the catalyst panel(s) in place.

**Note:** *Air flows in through the filter grille and out through the fan grille.*

13.) Reconnect 2 pin MOLEX connectors providing power to catalyst panel. See Figure 16.

14.) Reattach the lid and re-insert (6) screws and tightening with an Allen wrench. See Figure 13.

15.) Plug-in unit and power on to ensure that the unit works properly.

### Lamp Disposal

Products containing Mercury are considered hazardous waste. Since January 1, 2000, the United States Environmental Protection Agency (EPA) has allowed for spent lamps to be managed as Universal Wastes. The Universal Waste Rules (UWR) are designed in part to simplify the management of mercury containing wastes, including spent fluorescent lamps. The Rules are also intended to encourage recycling, thereby reducing mercury emissions to the environment.

As an alternative to managing lamps as universal wastes, a facility may elect to manage its spent lamps as hazardous wastes. Hazardous waste rules, like the universal waste rules, are promulgated under the federal Resource Conservation Recovery Act (RCRA) and state laws equivalent to RCRA. RCRA regulates hazardous waste from the cradle to the grave. RCRA Subtitle C requires a waste generator to properly identify, treat, store, transport, and delegate to the States the responsibility for the day-to-day management of the program.

### List of Lamp Recycling Facilities in the US

- AERC Recycling Solutions – Hayward, CA ; West Melbourne, FL ; Allentown, PA
- Universal Recycling Technologies – Dover, NH ; Clackamas, OR ; Fort Worth, TX ; Janesville, WI
- Veolia ES – Phoenix, AZ ; Tallahassee, FL ; Stoughton, MA ; Port Washington, WI

Go online to find your nearest lamp recycling facility.

# Ballast Tray Troubleshooting Procedure

## Troubleshooting All Fluorescent Fixtures

**Safety First:** Voltage and current measurements present the possibility of exposure to hazardous voltages and should be performed only by qualified personnel. Many troubleshooting techniques require measurements with input voltages applied requiring extra precautions to avoid electrical shock. Use proper safety equipment such as eye protection and gloves when performing electrical measurements.

### Inoperative Fixture:

Often, a fixture becomes inoperative due to causes not attributable to the ballast. It is important to examine all fixture components before removing the ballast for replacement. We recommend the following general procedure for both magnetic and electric ballasts:

- 1.) Replace or check all lamps to ensure satisfactory operation.
- 2.) As lamps are removed, examine all sockets to ensure they are not damaged or broken and are making proper contact with the lamps.
- 3.) Examine all electrical connection within the fixture, including at the lamp socket, to ensure conformance with the wiring diagram (see Wiring Diagram).

To left is a systematic approach for troubleshooting most problems than arise regarding fixture using ballasts with startup protection. For those situations when this document does not assist in correcting the problem, the manufacture should be contacted.

**Note:** Programmed Start Ballasts include lamp end-of-life circuitry. This circuit is included to maximize lamp life when one lamp fails in the circuit. The feature enables the ballast to detect when lamps fail and safely removes power for the lamp by going into a shutdown mode. The ballast also goes into a shutdown mode when it detects lamps not properly placed in the sockets. When troubleshooting the circuit, make sure lamps are placed properly in the sockets. Programmed Start ballasts also include a re-strike feature that will restart the lamps after the failed lamp has been replaced. Open circuit voltage cannot be measured due to lamp end-of-life circuitry.

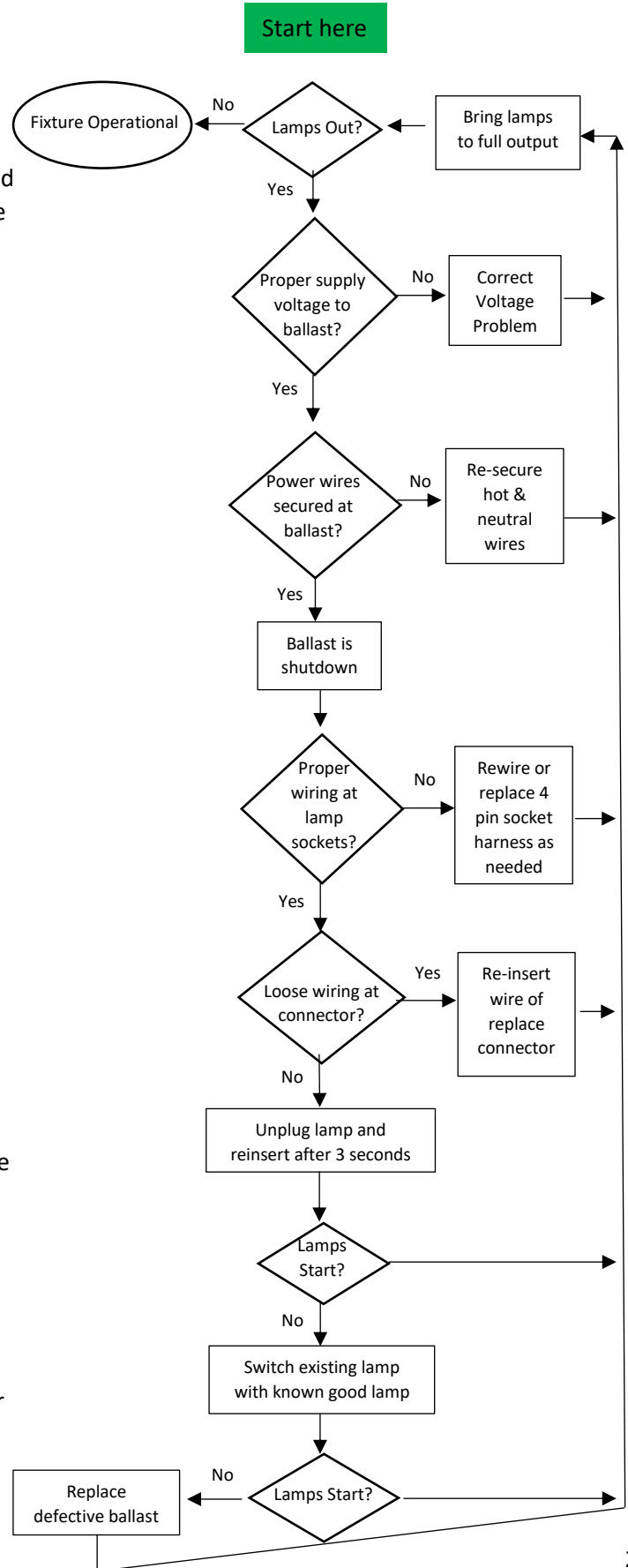

## Ballast Replacement.

There is not a set lifetime for ballasts. Ballasts are intended to last the life of the unit. However, ballasts can fail prematurely and will need to be replaced. Always replace them with ballasts sold through your CenterPoint air purifier supplier. See Ballast Troubleshooting for diagnosing ballast faults.

### Ballast Replacement Procedure

1.) Disconnect unit from power supply.

**Note:** *If the unit is powered on during lid removal, a safety switch will disconnect power.*

**Caution:** *Electrical plug must be disconnected before servicing. A break in power caused by the safety switch is not considered disconnecting power.*

2.) Remove top lid by unscrewing (6) screws with a 3.5 mm Allen wrench. When fitted with a hinge, the Condor will have fewer screws to remove. See Figure 13.

**Caution:** *If the Condor has been installed upside down, internal components may fall out when the lid is removed.*

3.) Disconnect the 2 pin MOLEX connector providing power to catalyst panel. See Figure 16.

4.) Remove catalyst panel(s) from the Condor. If the Condor has been installed upside down, remove the 10-16 Self-Drilling screws holding the catalyst panel(s) in place. Remove using a 5/16" socket. Be sure to hold panels while the screws are being removed to ensure that the panel does not fall out of housing.

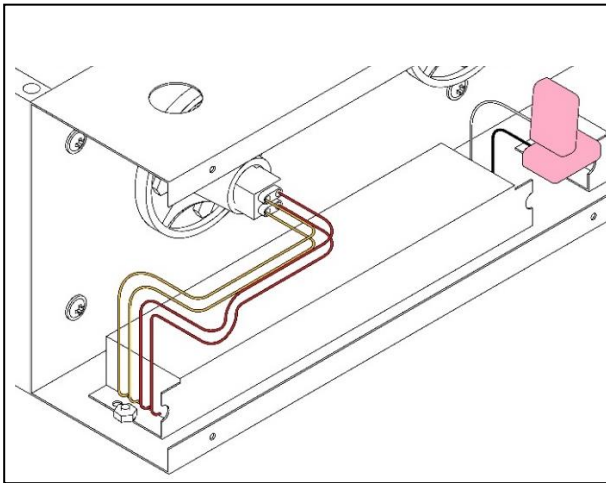

**Figure 21**

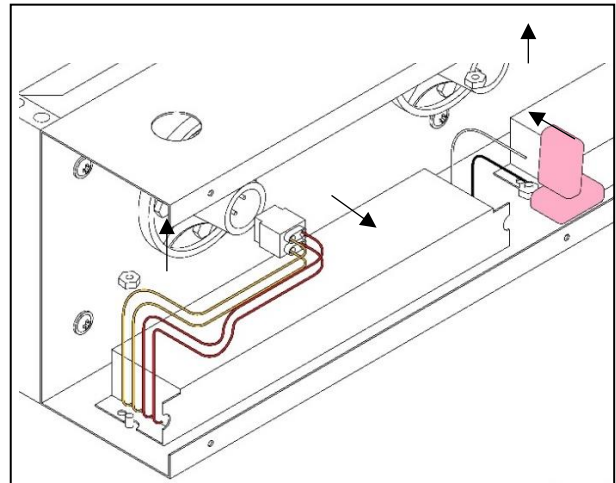

**Figure 22**

5.) Disconnect lamp plug and power attached to defective ballast. Take note of which terminals power the defective ballast so the new one can be wired correctly. See Figures 21 and 22.

**Caution:** *When removing lamp plugs, avoid wiggling plugs. This can cause excessive wear on contact pins.*

- 6.) Use an 11/32" socket wrench to remove the (2) nuts holding the ballast into place.
- 7.) Inspect the new ballast and ensure that it matches the original one being replaced.
- 8.) Reinsert and tighten the (2) nuts that hold the ballast in place with an 11/32" socket wrench. See Figures 21 and 22.
- 9.) Reconnect the lamp plugs and reconnect ballast wires into push-in connectors.
- 10.) Place catalyst panel(s) back into the Condor. Be sure that arrows on panel point in the direction of air flow. If the Condor is installed upside down, reinsert the 10-16 self-drilling screws into their original holes, holding the catalyst panel(s) in place.

**Note:** *Air flows in through the filter grille and out through the fan grille.*

- 11.) Reconnect 2 pin MOLEX connector providing power to catalyst panel. See Figure 16.
- 12.) Reattach the lid and re-insert (6) screws and tightening with an Allen wrench. See Figure 13.
- 13.) Plug-in unit and power on to ensure that the unit works properly.



## Fan Motor Replacement

Fan motors are intended to last the life of the unit. However, fan motors can fail prematurely and will need to be replaced. Always replace them with fan motors sold through your CenterPoint air purifier supplier.

### Fan Motor Replacement Procedure

1.) Disconnect unit from power supply.

**Note:** *If the unit is powered on during lid removal, a safety switch will disconnect power.*

**Caution:** Electrical plug must be disconnected before servicing. A break in power caused by the safety switch is not considered disconnecting power.

2.) Remove top lid by unscrewing (6) screws with a 3.5 mm Allen wrench. When fitted with a hinge, the Condor will have fewer screws to remove. See Figure 13.

**Caution:** *If the Condor has been installed upside down, internal components may fall out when the lid is removed.*

3.) Disconnect fan motor from wiring harness.

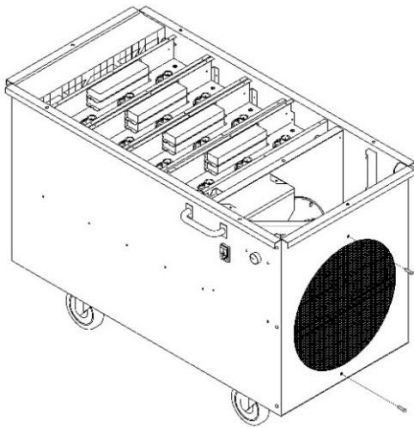

**Figure 23**

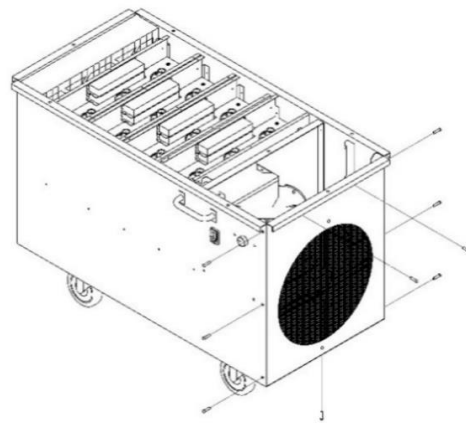

**Figure 24**

4.) Use an Allen wrench to remove (2) screws holding motor bracket to outlet grill. See Figure 21.

5.) Use an Allen wrench to remove (9) screws holding outlet grille in place. See Figure 22.

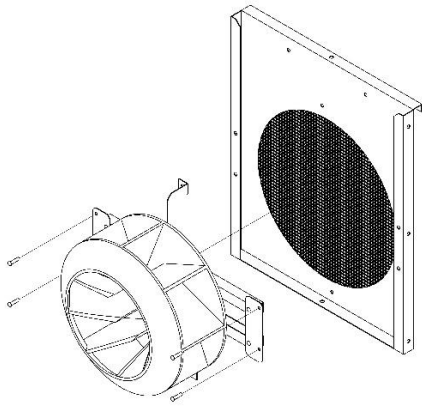

**Figure 25**

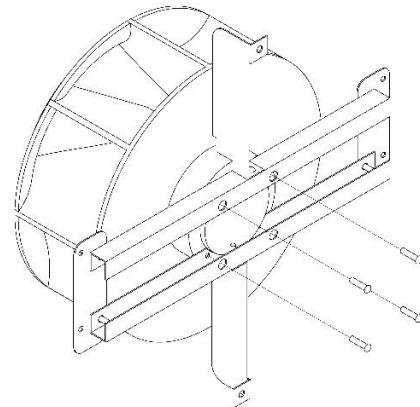

**Figure 26**

- 6.) Place outlet grille face down on a work surface and remove (4) screws holding motor bracket in place using an Allen wrench. See Figure 25.
- 7.) Place fan motor with the back side face up on work surface. Remove (4) screws holding fan motor to motor bracket using an Allen wrench. See Figure 26.
- 8.) Inspect the new fan motor and ensure that it matches the original.
- 9.) Place the new fan motor with the back side face up on the work surface. Insert (4) screws holding fan motor to motor bracket. Tighten screws using an Allen wrench. See Figure 26.
- 10.) Set outlet grille on a work surface face down. Attach motor bracket assembly to outlet grille with (4) screws. Use an Allen wrench to tighten screws. See Figure 25.
- 11.) Attach outlet grille to unit frame with (9) screws as shown in Figure 24. Use an Allen wrench to tighten screws.
- 12.) Insert (2) screws holding motor bracket to outlet grille. Use an Allen wrench to tighten screws. See Figure 23.
- 13.) Attach fan motor wiring clip to unit wiring harness.
- 14.) Reattach the lid and re-insert (6) screws and tightening with an Allen wrench. See Figure 13.
- 15.) Plug-in unit and power on to ensure that the unit works properly.

**Note:** *If the motor is installed incorrectly, the fan blade may rub on inlet ring. If this is the case, motor bracket may need to be repositioned.*

## Catalyst Cleaning

As debris and contaminants accumulate on the catalyst, the effectiveness of the unit decreases. The catalyst must be inspected periodically for buildup. It is recommended that this inspection be performed during pre-filter replacement. **However, frequent cleaning will reduce the life of the catalyst material.**

### Catalyst Inspection Procedure

1.) Disconnect unit from power supply.

**Note:** *If the unit is powered on during lid removal, a safety switch will disconnect power.*

**Caution:** *Electrical plug must be disconnected before servicing. A break in power caused by the safety switch is not considered disconnecting power.*

2.) Remove top lid by unscrewing (6) screws with a 3.5 mm Allen wrench. When fitted with a hinge, the Condor will have fewer screws to remove. See Figure 13.

**Caution:** *If the Condor has been installed upside down, internal components may fall out when the lid is removed.*

4.) Disconnect 2 pin MOLEX connector providing power to catalyst panel closes to pre-filter. This will be the dirtiest panel. See Figure 16.

5.) Remove the first catalyst panel from the Condor. If the Condor has been installed upside down, remove the 10-16 Self-Drilling screws holding the catalyst panel in place. Remove using a 5/16" socket. Be sure to hold panels while the screws are being removed to ensure that the panel does not fall out of housing.

6.) Using a flashlight, visually inspect catalyst. Look for clumps of dirt and debris.

7.) If the catalyst appears clean and free of particulate, the catalyst will not need to be cleaned. Proceed to the next step to reassemble. If catalyst has accumulated dirt and debris, the catalyst panel should be cleaned. Proceed to Catalyst Cleaning Procedure.

8.) Place catalyst panel(s) back into the Condor. Be sure that arrows on panel point in the direction of air flow. If the Condor is installed upside down, reinsert the 10-16 self-drilling screws into their original holes, holding the catalyst panel(s) in place.

**Note:** *Air flows in through the filter grille and out through the fan grille.*

9.) Reconnect 2 pin MOLEX connector providing power to catalyst panel. See Figure 16.

10.) Reattach the lid and re-insert (6) screws and tightening with an Allen wrench. See Figure 13.

11.) Plug-in unit and power on to ensure that the unit works properly.

### Catalyst Cleaning Procedure

1.) Disconnect unit from power supply.

**Note:** *If the unit is powered on during lid removal, a safety switch will disconnect power.*

**Caution:** *Electrical plug must be disconnected before servicing. A break in power caused by the safety switch is not considered disconnecting power.*

2.) Remove top lid by unscrewing (6) screws with a 3.5 mm Allen wrench. When fitted with a hinge, the Condor will have fewer screws to remove.

**Caution:** *If the Condor has been installed upside down, internal components may fall out when lid is removed.*

3.) Disconnect 2 pin MOLEX connector providing power to catalyst panel closes to pre-filter. This will be the dirtiest panel. See Figure 16.

4.) Remove first catalyst panel from the Condor. If the Condor has been installed upside down, remove the 10-16 Self-Drilling screws holding the catalyst panel in place. Remove using a 5/16" socket. Be sure to hold panels while the screws are being removed to ensure that the panel does not fall out of housing.

5.) If the catalyst has only light to moderate dust build up, use a pump-up spray bottle with water only to rinse the catalyst. Avoid heavy concentration of spray on ballast tray.

If the catalyst is soiled with resin (E.T.S.) or grease, spray the catalyst liberally with Nu-Calgon CalClean, Special HD, or another suitable coil cleaner. Do not spray ballast tray. Allow catalyst to sit for 15 minutes before rinsing with pump-up water spray bottle.

If the catalyst has been discolored, a mixture of powered Oxiclean and water can be sprayed on the catalyst with a pump-up spray bottle. Allow to sit for 15 minutes before rinsing with pump up water spray bottle.

**Caution:** *Do not spray high-pressure water to clean the catalyst. Excessive use of high-pressure water will remove catalyst coating. This type of damage will void the product warranty.*

6.) Allow catalyst to dry before reinserting into unit.

7.) Place catalyst panel(s) back into the Condor. Be sure that arrows on panel point in the direction of air flow. If the Condor is installed upside down, reinsert the 10-16 self-drilling screws into their original holes, holding the catalyst panel(s) in place.

**Note:** *Air flows in through the filter grille and out through the fan grille.*

8.) Reconnect 2 pin MOLEX connector providing power to catalyst panel. See Figure 16.

9.) Reattach the lid and re-insert (6) screws and tightening with an Allen wrench. See Figure 13.

10.) Plug-in unit and power on to ensure that the unit works properly.

## Catalyst Replacement

After 15 years of continuous use, the catalyst panel inside the unit will need to be replaced. Over time the UV lights will degrade the TiO<sub>2</sub> coating, exposing the fiberglass core. In Figure 27, notice the stripes in the mesh created by the lamps. It is time to replace the catalyst when these stripes appear. Figures 28 and 29 show the removal of catalyst windowing over time. When the windowing is removed, the catalyst is not effective at creating hydroxyl radicals.



**Striped Catalyst: Figure 27**



**Used Catalyst Windowing: Figure 28**



**New Catalyst Windowing: Figure 29**

**Note:** Upon initial startup, some window coating may be blown out of the panel due to excessive coating. At a minimum, 40% of windowing is required for the catalyst panels to meet factory specifications. If the windowing drops below 40%, the catalyst panel should be replaced.

### Catalysis Replacement Procedure

1.) Disconnect unit from power supply.

**Note:** If the unit is powered on during lid removal, a safety switch will disconnect power.

**Caution:** Electrical plug must be disconnected before servicing. A break in power caused by the safety switch is not considered disconnecting power.

2.) Remove top lid by unscrewing (6) screws with a 3.5 mm Allen wrench. When fitted with a hinge, the Condor will have fewer screws to remove. See Figure 13.

**Caution:** *If the Condor has been installed upside down, internal components may fall out when lid is removed.*

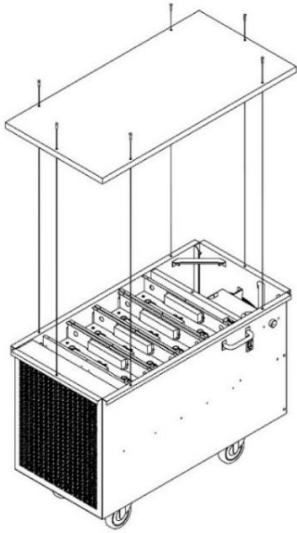

**Figure 30**

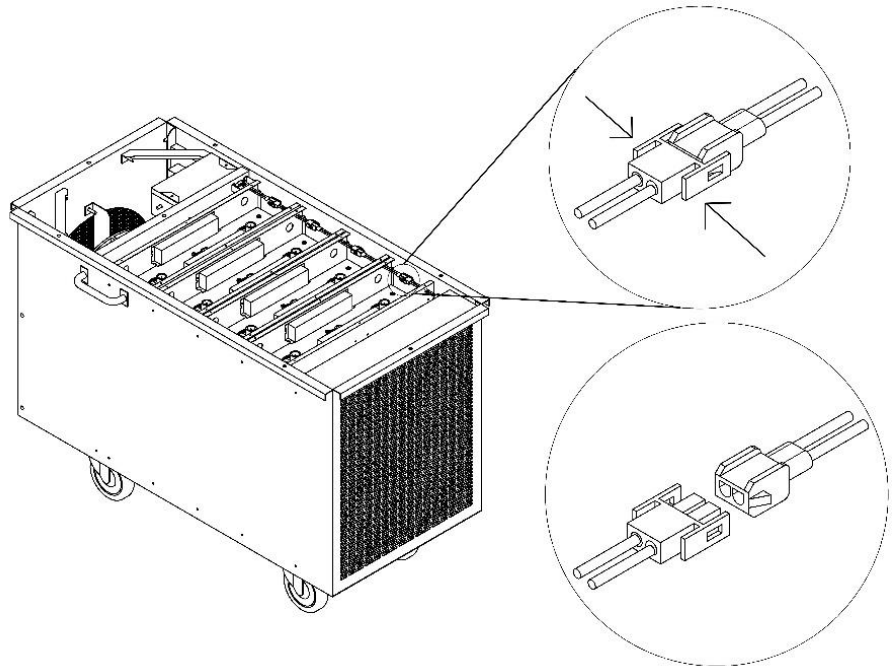

**Figure 31**

3.) Disconnect 2 pin MOLEX connector providing power to Catalyst Panel. See Figure 30.

4.) Remove catalyst panel(s) from the Condor. If the Condor has been installed upside down, remove the 10-16 Self-Drilling screws holding the catalyst panel(s) in place. Remove using a 5/16" socket. Be sure to hold panels while the screws are being removed to ensure that the panel does not fall out of housing.

5.) Replace catalyst panel(s) with part number 2021 PCP.

6.) Place new catalyst panel(s) into the Condor. Be sure that the wire mesh is on the airflow outlet side of the panel. If the Condor is installed upside down, reinsert the 10-16 self-drilling screws into their original holes, holding the catalyst panel(s) in place.

**Note:** *Air flows in through the filter grille and out through the fan grille.*

7.) Reconnect 2 pin MOLEX connectors providing power to catalyst panel. See Figure 31.

8.) Reattach the lid and re-insert (6) screws and tightening with an Allen wrench. See Figure 30.

9.) Plug-in unit and power on to ensure that the unit works properly.

## Fuse Replacement

This unit utilizes two fuses to prevent high current flow if an electrical short were to occur. If the unit will not operate when power is turned ON, there is a possibility that there is a blown fuse. Each Power Entry Module (PEM) is equipped with one spare fuse. Replacement fuses should be 5 mm in diameter and 20 mm in length glass fuses with a current rating of 8 to 12 amps.

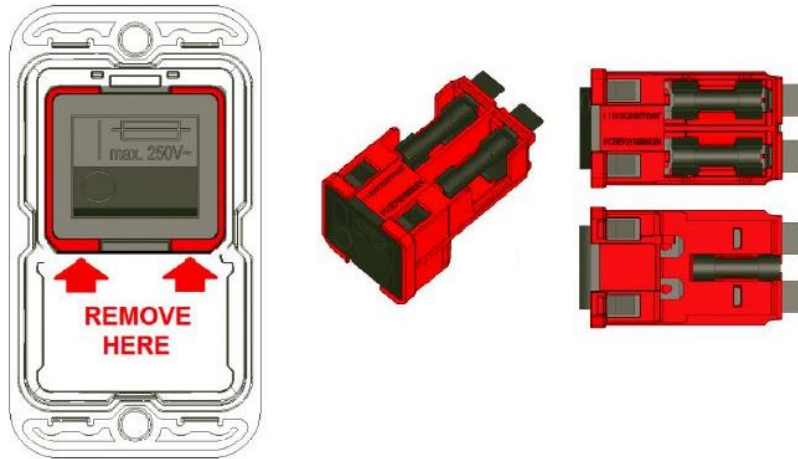

Figure 32

### Fuse Replacement Procedure

1.) Disconnect power cord from unit.

**Note:** *The fuse holder cannot be removed unless the power cord is first removed.*

**Caution:** *Electrical plug must be disconnected before servicing. A break in power caused by the safety switch is not considered disconnecting power.*

2.) Place the end of a 1/8" flat head screwdriver into one of the holes in bottom of the fuse holder. Pry the fuse holder out of the power entry module. See Figure 32.

2.) Check the Power and Neutral wire fuses. If a fuse has blown, replace it with the spare fuse.

3.) Carefully place the fuse holder back into the power entry module.

4.) Plug-in unit and power on to ensure that the unit works properly.

### **Exterior Cleaning Method**

**Caution:** *Disconnect device from power prior to cleaning.*

Dampen a soft cloth with lukewarm water. Wipe the exterior of the device with a cloth.

**Caution:** *Do not wipe the device with an alkaline solution (ex: baking soda and water). Do not wipe the device with an acidic solution (ex: hydrochloric acid or vinegar). Do not wipe the device with an organic solvent (ex: thinner, kerosene, acetone, alcohol). Only use water to avoid damage to the product surface.*

## Replacement Parts

Part	Description	Name / Model Number
Ballast	120 VAC, 60 Hz	Fulham WH-5
Catalyst	19.5" x 24" x 5.8"	2021 PCP
Standard Pre-filter	20" x 24" x 4"	20" x 24" x 4" MERV 13 Filter
V-Bank Carbon Filter	20" x 24" x 12"	D-Mark AAC-12-100-06
HEPA Filter	20" x 24" x 6"	20" x 24" x 6" HEPA Filter
Motor Assembly	Large AC Fan, CFM	TMK335-4-11
UVGI Lamps	20" UV-C Lamp	First Light 2813, UV Engineering GEN9093
UVGI Shielding	20" x 24"	UV Shield
Capacitor	40 $\mu$ F	Ducati Energia Spa 40 $\mu$ F Capacitor
Power Cord	16 AWG, Type C13	Qualtek Electronics Corp. 233058-01
Motor Controller	Steady State Speed Controller	KBWC-115k
Lamp Screws	Hex Screw	10-16 Self-Drilling Screw
Catalyst Cover Screws	Phillips Head Screw	PPH 1/2" Self-Drilling Screw
Lid Screws	Condor Lid Screws	M6-1.0 x 16 SHCS
Lid Hinge	Condor Lid Hinge	Piano Hinge
Caster Wheels	Condor Wheels	Caster; Swivel; 5 x 1-1/4; Polypropylene; PREC; PLT; 35

**Table 2: Replacement Parts**

*\*Only use genuine replacement parts. Parts highlighted in gray may be substituted with other manufactures.*

To place an order for replacement parts, please contact the manufacture at

Phone: (806)745-7000

Website: [www.genesisair.com](http://www.genesisair.com)



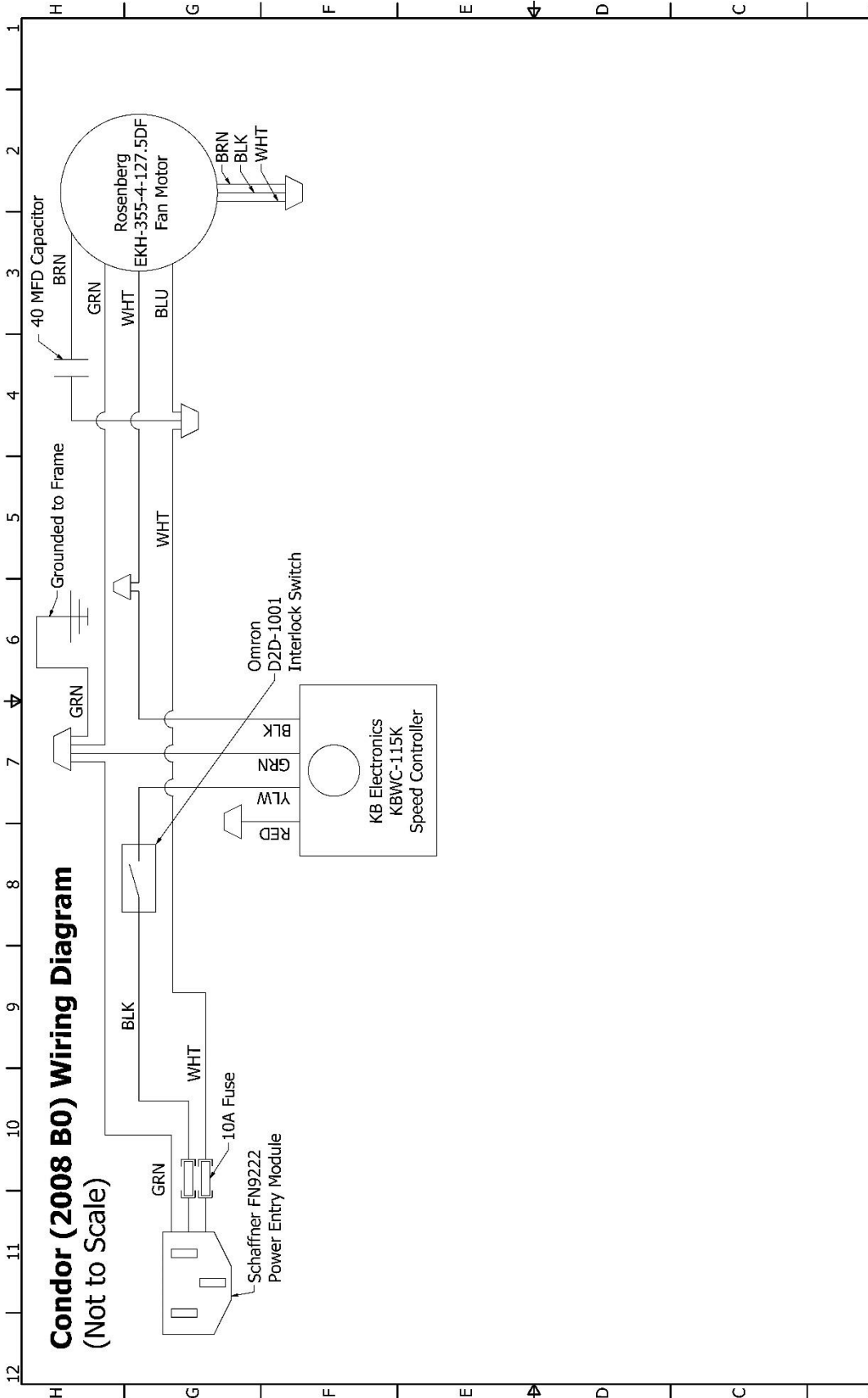

<p><b>Notes:</b></p> <ol style="list-style-type: none"> <li>Speed Control Type: Triac Variable Speed Control</li> <li>PCP Count: (0) 2021 PCP</li> <li>Lamp Count: (0) 20" UV-C Lamps</li> <li>Voltage Rating: 120VAC @ 50/60 Hz</li> <li>Current Draw: 5.40A</li> <li>Power Consumption: 648 Watts</li> <li>Isolation Transformer Count: (0)</li> </ol>		<p>Unless otherwise specified, dimensions are in inches. Tolerances are:          Decimals: .015          .XX: .03          .XXX: ± 0.010</p>	
<p><b>GENESIS AIR, INC.</b></p>		<p>Unit: CONDOR (2008 B0)</p>	
<p>Material:</p>		<p>Part:</p>	
<p>Weight (lbs):</p>		<p>Quantity:</p>	
<p>Proprietary and Confidential www.genesisair.com</p>		<p>Drawing By: CONNOR CROAK</p>	
<p>Date: 5/16/2024</p>			

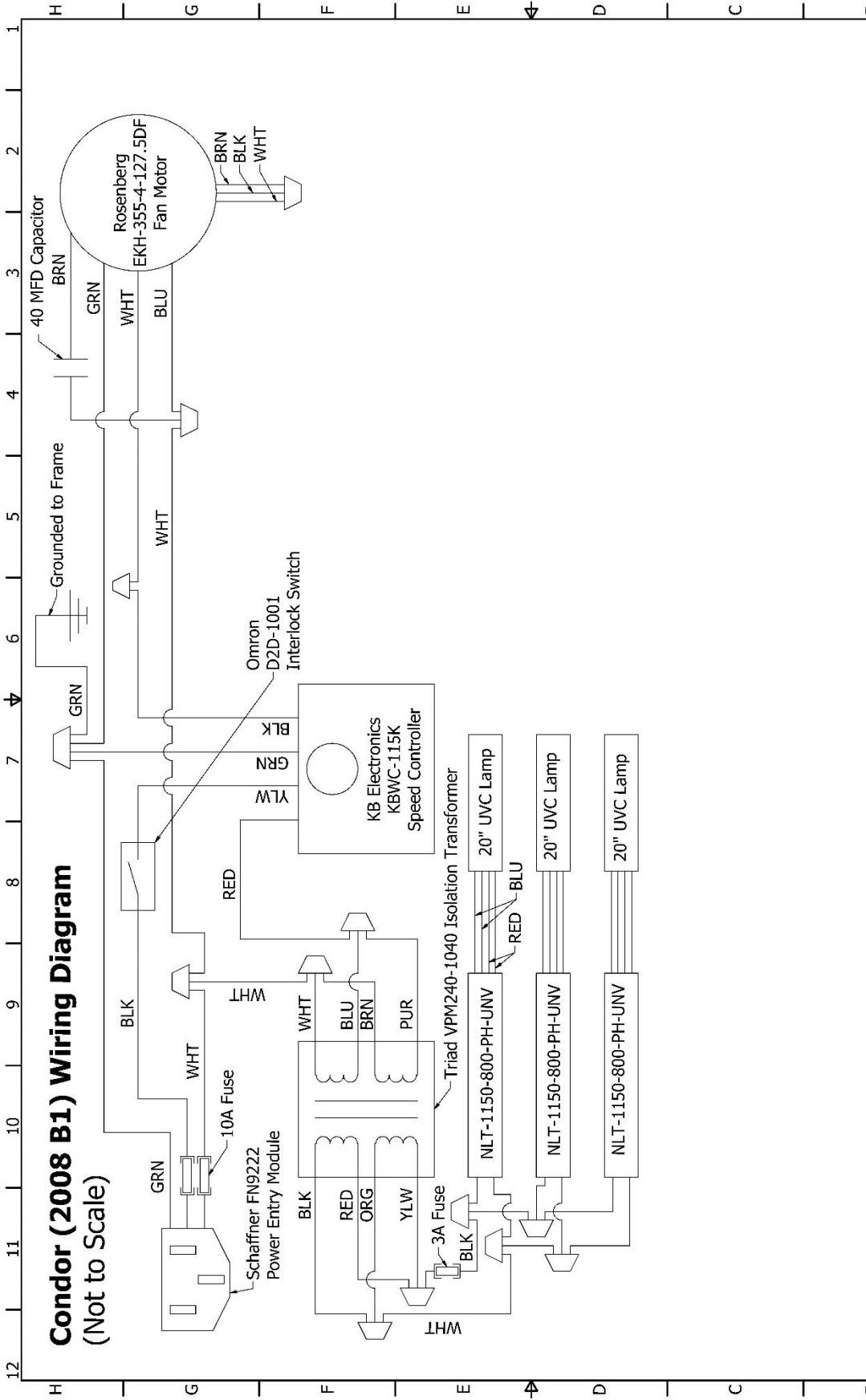

**Condor (2008 B1) Wiring Diagram**  
(Not to Scale)

<p><b>Notes:</b></p> <ol style="list-style-type: none"> <li>Speed Control Type: Triac Variable Speed Control</li> <li>PCP Count: (1) 2021 PCP</li> <li>Lamp Count: (3) 20" UV-C Lamps</li> <li>Voltage Rating: 120VAC @ 50/60 Hz</li> <li>Current Draw: 6.45A</li> <li>Power Consumption: 774 Watts</li> <li>Isolation Transformer Count: (1)</li> </ol>		 <p>CREATING CLEAN AIR TO BREATHE</p> <p>Proprietary and Confidential www.genesisair.com</p>		<p>Unless otherwise specified, dimensions are in inches: Decimal XX ± 0.03 XXX ± 0.010</p>		<p><b>GENESIS AIR, INC.</b></p> <p>Unit: CONDOR (2008 B1)</p> <p>Part:</p> <p>Quantity:</p> <p>Drawing By: CONNOR CROAK</p> <p>Date: 7/1/2024</p>	
--	--	--	--	--	--	---	--

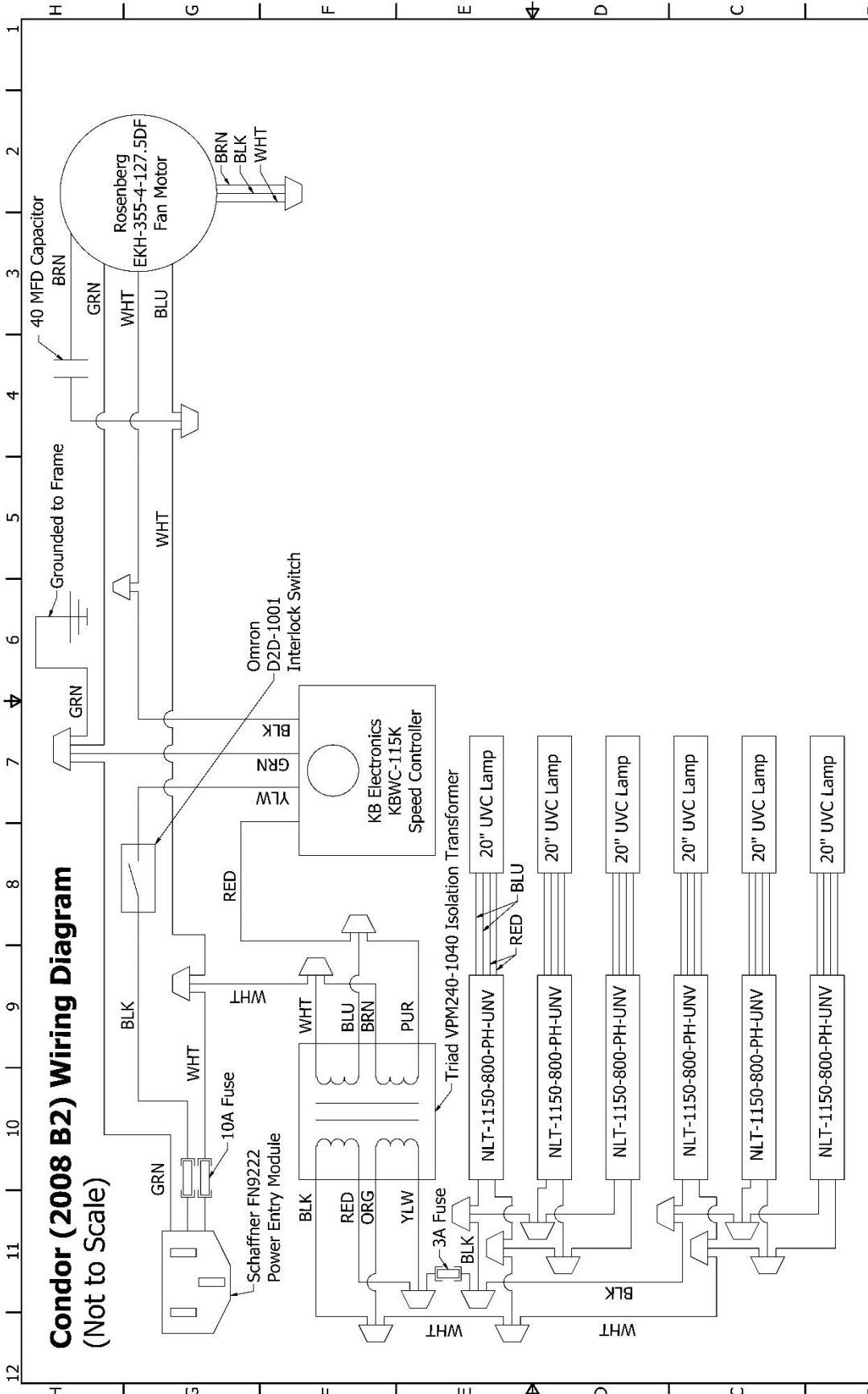

<p><b>Notes:</b></p> <ol style="list-style-type: none"> <li>Speed Control Type: Triac Variable Speed Control</li> <li>PCP Count: (2) 2021 PCP</li> <li>Lamp Count: (6) 20" UV-C Lamps</li> <li>Voltage Rating: 120VAC @ 50/60 Hz</li> <li>Current Draw: 7.50A</li> <li>Power Consumption: 900 Watts</li> <li>Isolation Transformer Count: (1)</li> </ol>		<p>Unless otherwise specified, dimensions are in inches. Tolerances are: Decimal XX ± 0.03 XXX ± 0.010</p>	
<p><b>GENESIS AIR, INC.</b></p> <p>Unit: CONDOR (2008 B2)</p>		<p>Part:</p>	
<p>Material:</p>		<p>Weight (lbs):</p>	
<p>Proprietary and Confidential www.genesisair.com</p>		<p>Drawing By: CONNOR CROAK</p>	
<p>CREATING CLEAN AIR TO BREATHE</p>		<p>Date: 7/1/2024</p>	

# Condor (2008 B3) Wiring Diagram (Not to Scale)

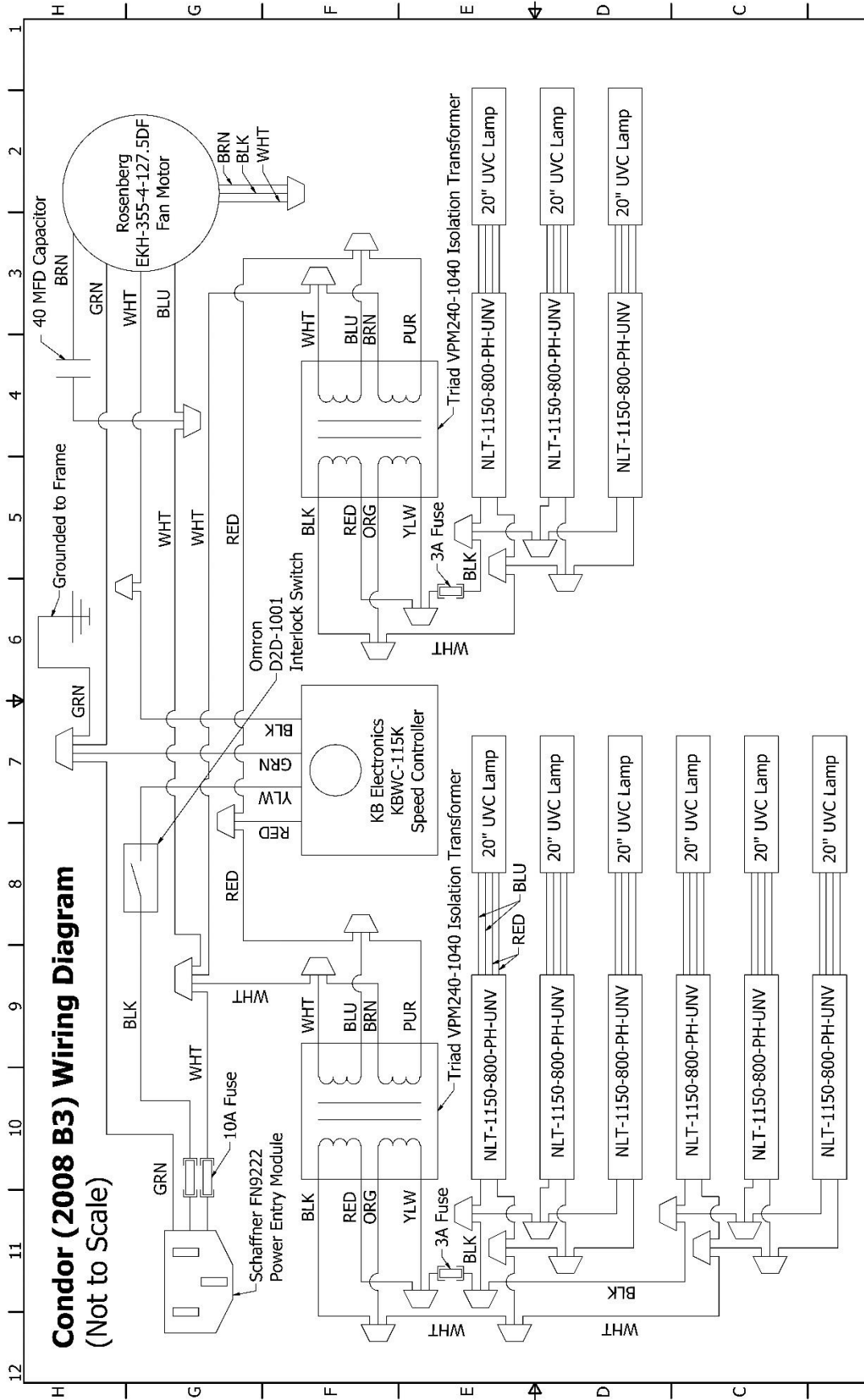

<p><b>Notes:</b></p> <ol style="list-style-type: none"> <li>Speed Control Type: Triac Variable Speed Control</li> <li>PCP Count: (3) 2021 PCP</li> <li>Lamp Count: (9) 20" UV-C Lamps</li> <li>Voltage Rating: 120VAC @ 50/60 Hz</li> <li>Current Draw: 8.55A</li> <li>Power Consumption: 1026 Watts</li> <li>Isolation Transformer Count: (2)</li> </ol>		<p>GENESIS AIR, INC.</p> <p>Unit: CONDOR (2008 B3)</p> <p>Part:</p> <p>Quantity:</p> <p>Drawing By: CONNOR CROAK</p> <p>Date: 7/1/2024</p>	
<p>Unless otherwise specified, dimensions are in inches.</p> <p>Tolerances are:</p> <p>Decimal XX ± 0.03 XXX ± 0.010</p>		<p>Material:</p> <p>Weight (lbs):</p>	
<p>CREATING CLEAN AIR TO BREATHE</p> <p>Proprietary and Confidential www.genesisair.com</p>			

# Condor (2008 B4) Wiring Diagram (Not to Scale)

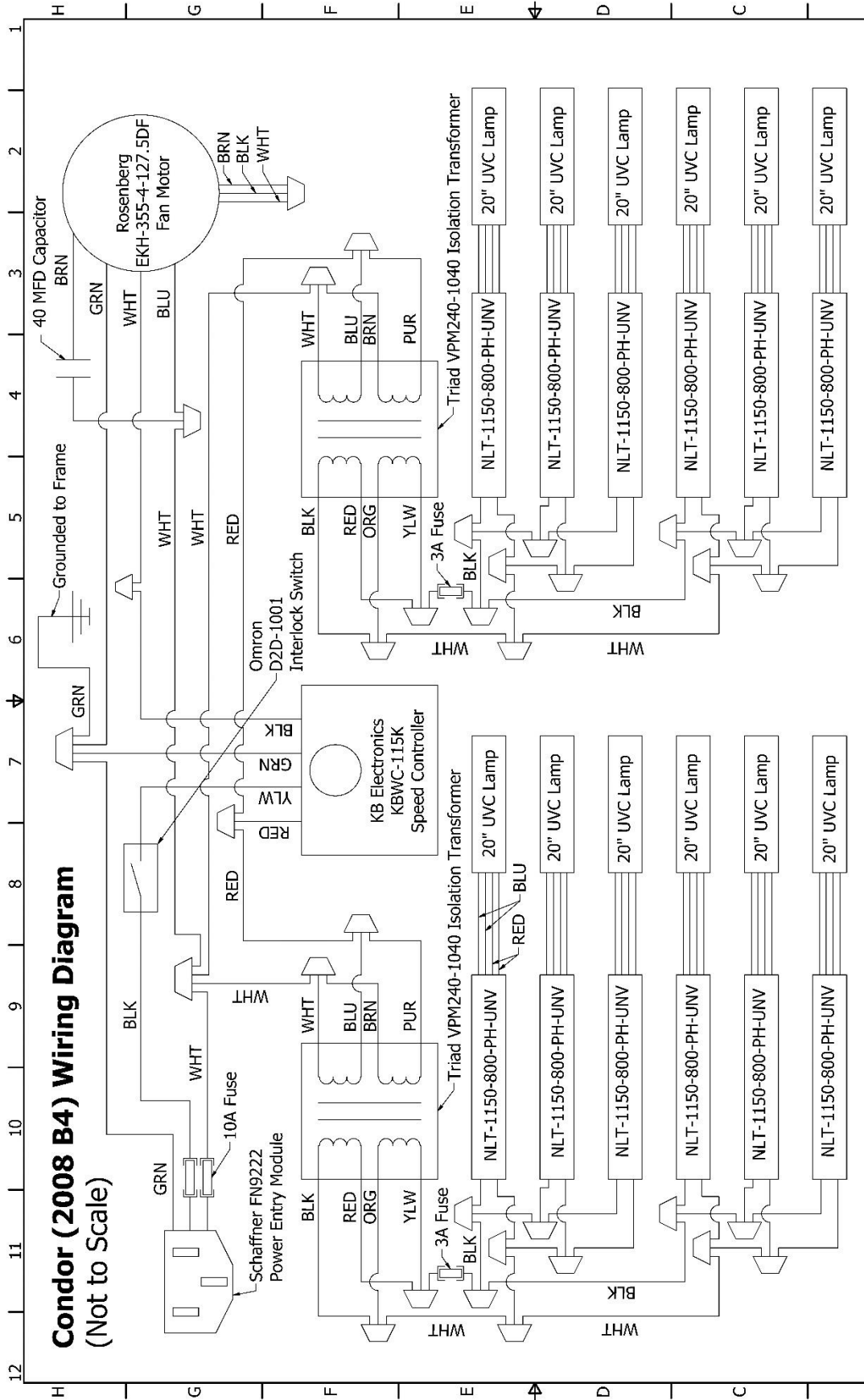

- Notes:**
1. Speed Control Type: Triac Variable Speed Control
  2. PCP Count: (4) 2021 PCP
  3. Lamp Count: (12) 20" UV-C Lamps
  4. Voltage Rating: 120VAC @ 50/60 Hz
  5. Current Draw: 9.60A
  6. Power Consumption: 1152 Watts
  7. Isolation Transformer Count: (2)



**GENESIS AIR**  
CREATING CLEAN AIR TO BREATHE

Proprietary and Confidential  
www.genesisair.com

<b>GENESIS AIR, INC.</b>	
Unit: CONDOR (2008 B4)	
Part:	
Quantity:	
Drawing By: CONNOR CROAK	
Date: 7/1/2024	

Unless otherwise specified, dimensions are in inches:  
 Decimal: XX ± 0.03  
 Fractional: XXX ± 0.010

# Air Purification Testing

The manufacturer has conducted numerous tests to authenticate that CenterPoint™ technology is an effective means of reducing airborne indoor air contaminants. The manufacturer of this device will make copies of test results available to those who request it.

## Testing Protocol

There are two main types of tests that can be performed with air purifying equipment: single pass tests and chamber tests. A single pass test measures the contaminant level at the inlet of the equipment and compares that value to the level of contaminants at the outlet. A chamber test measures the change in contaminant level within an enclosed space over a given amount of time. Tests can measure volatile organic compounds (VOCs) reduction, reduction of viable biological contaminants (bacteria, viruses, fungi), and particulate reduction.

CenterPoint equipment is intended to reduce VOCs and deactivate viable biological contaminants. **CenterPoint equipment is not intended to significantly reduce non-viable biological contaminants. CenterPoint equipment is not intended to significantly reduce particle contaminants.**

Many testing groups do not make a distinction between viable and non-viable biological contaminants. When testing CenterPoint equipment, a distinction must be made between viable and non-viable biological contaminants in the air. **Tests must only measure viable biological contaminants that appear in the air.** The bodies of inactivated biological contaminants will remain in the air. **Inactive bodies are incapable of reproducing or infecting people occupying the space.**

For more information, please contact the manufacturer at

Email: [info@genesisaair.com](mailto:info@genesisaair.com)

## **LIMITED WARRANTY**

### **FAILURE TO MAINTAIN YOUR EQUIPMENT WILL VOID THIS WARRANTY**

Your CenterPoint purification system is expressly warranted from the date of installation to be free from manufacturing defects for the coverage period stated below. Defective parts must be returned by you to the installation contractor together with the CenterPoint purification system's model number, serial number, and documented installation date no later than thirty (30) days after the failure.

### **ONE (1) YEAR COVERAGE -- RESIDENTIAL AND COMMERCIAL APPLICATIONS**

The covered equipment and covered components are warranted by Genesis Air for a period of ONE (1) year from the date of the original unit installation, when installed in a residential or commercial application. If during this period, a covered component fails because of a manufacturing defect, Genesis Air will provide a free replacement part. You must pay shipping charges and all other costs of warranty service. Genesis Air will not pay labor involved in diagnostic calls or in removing, repairing, servicing, or replacing parts. Such costs may be covered by a separate warranty provided by the installer. NOTE - If the date of original installation cannot be verified, the warranty period will be deemed to begin six (6) months after the date of manufacture.

### **EXCLUDED COMPONENTS**

The following components are not covered by this warranty: the UVCGI lamps or the pleated photocatalytic material. These are replacement items, which must be replaced as stated in the Maintenance section of the installation instructions to ensure effective operation.

### **REPAIRS**

All repairs of covered components must be made with authorized service parts by a qualified service dealer or contractor. Labor charges are not covered by this warranty.

### **WARRANTY LIMITATIONS**

This warranty will be voided if the covered equipment is removed from the original installation site. This warranty does not cover damage or defect resulting from:

- 1** - Flood, wind, fire, or lightning damage. Storage, installation, or operation in a corrosive atmosphere (chlorine, fluorine, salt, recycled wastewater, urine, fertilizers, or other damaging chemicals).
- 2** - Accident, or neglect or unreasonable use or operation of the equipment, including operation of electrical equipment at voltages other than the range specified on the unit nameplate (Includes damage caused by brownouts).
- 3** - Modification, change or alteration of the equipment, except as directed by the manufacturer.
- 4** - Operation with system components (indoor unit and control devices), which do not match, or meet the specifications recommended by the manufacturer.
- 5** - Operation with system components (indoor unit and control devices), which exceed operational temperature range of; -20 F to 122F.
- 6** – **Cleaning equipment with high pressure water spray so that the PCP catalyst coating is damaged.**
- 7** – Damage caused by allowing non-functioning equipment to be in an air stream for a prolonged period. Air speeds above 600 ft/min will damage equipment beyond repair.

THIS WARRANTY SHALL NOT OBLIGATE THE MANUFACTURER FOR ANY LABOR COSTS AND SHALL NOT APPLY TO DEFECTS IN WORKMANSHIP OR MATERIALS FURNISHED BY THE INSTALLING CONTRACTOR AS CONTRASTED TO DEFECTS IN THE CENTERPOINT PURIFICATION SYSTEM ITSELF. IMPLIED WARRANTIES OF MERCHANTABILITY OR FITNESS FOR A PARTICULAR PURPOSE SHALL BE LIMITED IN DURATION TO THE AFORESAID COVERAGE PERIOD. THE MANUFACTURER'S LIABILITY FOR INCIDENTAL OR CONSEQUENTIAL DAMAGES, OTHER THAN DAMAGES FOR PERSONAL INJURIES, RESULTING FROM ANY BREACH OF THE AFORESAID IMPLIED WARRANTIES OR THE ABOVE LIMITED WARRANTY IS EXPRESSLY EXCLUDED. THIS LIMITED WARRANTY IS VOID IF DEFECT(S) RESULT FROM FAILURE TO HAVE THIS UNIT INSTALLED BY A QUALIFIED HEATING AND AIR CONDITIONING CONTRACTOR. IF THE LIMITED WARRANTY IS VOID DUE TO FAILURE TO USE A QUALIFIED CONTRACTOR, ALL DISCLAIMERS OF IMPLIED WARRANTIES SHALL BE EFFECTIVE UPON INSTALLATION.

Some states do not allow limitations on how long an implied warranty lasts or the exclusion or limitation of incidental or consequential damages, so the above exclusion or limitations may not apply to you. This warranty gives you specific legal rights and you may also have other rights, which vary from state to state.

**Last Revision: 10/21/2021**

**To register your new CenterPoint™ Purification System, PLEASE CUT ON DOTTED LINE AND RETURN THE REGISTRATION FORM TO THE ADDRESS NOTED BELOW.**

-----  
**Customer Registration Form**

Customer Name: \_\_\_\_\_ Address: \_\_\_\_\_

City: \_\_\_\_\_ State/Province: \_\_\_\_\_ Zip/Postal Code: \_\_\_\_\_

Home Phone: \_\_\_\_\_ E-mail: \_\_\_\_\_

Installing Contractor: \_\_\_\_\_ Phone: \_\_\_\_\_

Date of installation: \_\_\_\_\_ Model Number: \_\_\_\_\_ Serial Number: \_\_\_\_\_

Please send this completed form to the manufacturer.

Genesis Air, Inc.

5202 CR 7350, SUITE D LUBBOCK, TX 79424

